

Installation, Operation, and Maintenance

Packaged Rooftop Air Conditioners

Voyager™ – Heat Pump

12.5 to 20 Tons, 60/50 Hz

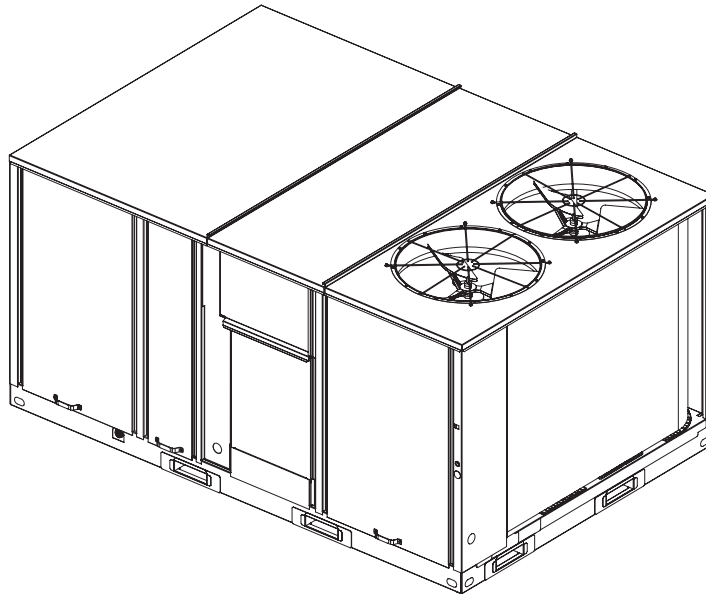

Model Number: WS*150-240

⚠ SAFETY WARNING

Only qualified personnel should install and service the equipment. The installation, starting up, and servicing of heating, ventilating, and air-conditioning equipment can be hazardous and requires specific knowledge and training. Improperly installed, adjusted or altered equipment by an unqualified person could result in death or serious injury. When working on the equipment, observe all precautions in the literature and on the tags, stickers, and labels that are attached to the equipment.

April 2020

RT-SVX33J-EN

Introduction

Read this manual thoroughly before operating or servicing this unit.

Warnings, Cautions, and Notices

Safety advisories appear throughout this manual as required. Your personal safety and the proper operation of this machine depend upon the strict observance of these precautions.

The three types of advisories are defined as follows:

⚠ WARNING Indicates a potentially hazardous situation which, if not avoided, could result in death or serious injury.

⚠ CAUTION Indicates a potentially hazardous situation which, if not avoided, could result in minor or moderate injury. It could also be used to alert against unsafe practices.

NOTICE Indicates a situation that could result in equipment or property-damage only accidents.

Important Environmental Concerns

Scientific research has shown that certain man-made chemicals can affect the earth's naturally occurring stratospheric ozone layer when released to the atmosphere. In particular, several of the identified chemicals that may affect the ozone layer are refrigerants that contain Chlorine, Fluorine and Carbon (CFCs) and those containing Hydrogen, Chlorine, Fluorine and Carbon (HCFCs). Not all refrigerants containing these compounds have the same potential impact to the environment. Trane advocates the responsible handling of all refrigerants-including industry replacements for CFCs and HCFCs such as saturated or unsaturated HFCs and HCFCs.

Important Responsible Refrigerant Practices

Trane believes that responsible refrigerant practices are important to the environment, our customers, and the air conditioning industry. All technicians who handle refrigerants must be certified according to local rules. For the USA, the Federal Clean Air Act (Section 608) sets forth the requirements for handling, reclaiming, recovering and recycling of certain refrigerants and the equipment that is used in these service procedures. In addition, some states or municipalities may have additional requirements that must also be adhered to for responsible management of refrigerants. Know the applicable laws and follow them.

⚠ WARNING

Proper Field Wiring and Grounding Required!

Failure to follow code could result in death or serious injury. All field wiring **MUST** be performed by qualified personnel. Improperly installed and grounded field wiring poses **FIRE** and **ELECTROCUTION** hazards. To avoid these hazards, you **MUST** follow requirements for field wiring installation and grounding as described in **NEC** and your local/state electrical codes.

⚠ WARNING

Personal Protective Equipment (PPE) Required!

Failure to wear proper PPE for the job being undertaken could result in death or serious injury. Technicians, in order to protect themselves from potential electrical, mechanical, and chemical hazards, **MUST** follow precautions in this manual and on the tags, stickers, and labels, as well as the instructions below:

- Before installing/servicing this unit, technicians **MUST** put on all PPE required for the work being undertaken (Examples; cut resistant gloves/sleeves, butyl gloves, safety glasses, hard hat/bump cap, fall protection, electrical PPE and arc flash clothing). **ALWAYS** refer to appropriate Safety Data Sheets (SDS) and OSHA guidelines for proper PPE.
- When working with or around hazardous chemicals, **ALWAYS** refer to the appropriate SDS and OSHA/GHS (Global Harmonized System of Classification and Labeling of Chemicals) guidelines for information on allowable personal exposure levels, proper respiratory protection and handling instructions.
- If there is a risk of energized electrical contact, arc, or flash, technicians **MUST** put on all PPE in accordance with OSHA, NFPA 70E, or other country-specific requirements for arc flash protection, **PRIOR** to servicing the unit. **NEVER PERFORM ANY SWITCHING, DISCONNECTING, OR VOLTAGE TESTING WITHOUT PROPER ELECTRICAL PPE AND ARC FLASH CLOTHING. ENSURE ELECTRICAL METERS AND EQUIPMENT ARE PROPERLY RATED FOR INTENDED VOLTAGE.**

WARNING

Follow EHS Policies!

Failure to follow instructions below could result in death or serious injury.

- **All Trane personnel must follow the company's Environmental, Health and Safety (EHS) policies when performing work such as hot work, electrical, fall protection, lockout/tagout, refrigerant handling, etc. Where local regulations are more stringent than these policies, those regulations supersede these policies.**
- **Non-Trane personnel should always follow local regulations.**

Copyright

This document and the information in it are the property of Trane, and may not be used or reproduced in whole or in part without written permission. Trane reserves the right to revise this publication at any time, and to make changes to its content without obligation to notify any person of such revision or change.

Trademarks

All trademarks referenced in this document are the trademarks of their respective owners.

Factory Training

Factory Training is available through Trane University™ to help you learn more about the operation and maintenance of your equipment. To learn about available training opportunities contact Trane University™.

Online: www.trane.com/traneuniversity

Phone: 855-803-3563

Email: traneuniversity@trane.com

Revision History

- Updated Model Number Description and Maintenance sections.
- Added Sequence of Operation section.

Table of Contents

| | | | |
|--|----|---|----|
| Model Number Description | 5 | Fan Failure Switch | 53 |
| General Information | 7 | Condensate Overflow Switch | 53 |
| Overview of Manual | 7 | Zone Temperature Sensor (ZTS) Tests ... | 53 |
| Unit Inspection | 7 | Programmable & Digital Zone Sensor Test | 54 |
| Storage | 7 | Wiring Diagrams | 56 |
| Unit Clearances | 8 | Warranty | 57 |
| Unit Description | 8 | Heat Pump | 57 |
| ReliaTel™ Control | 8 | | |
| System Input Devices and Functions | 8 | | |
| Zone Sensors | 10 | | |
| Unit Dimensions | 12 | | |
| Unit Weights | 18 | | |
| Installation | 19 | | |
| Factory-Mounted Unit Options | 27 | | |
| Circuit Breaker (FIYUCB) and Unit Disconnect (FIYUDC) | 27 | | |
| Powered/Unpowered Convenience Outlet | 28 | | |
| Return Air Smoke Detector | 29 | | |
| Air-Fi™ Wireless Communication Interface (WCI) | 32 | | |
| Pre-Start | 33 | | |
| Start Up | 35 | | |
| Sequence of Operation | 37 | | |
| ReliaTel Controls | 37 | | |
| Two-Speed Indoor Fan (Title 24) Control . | 39 | | |
| Single Zone Variable Air Volume (Single Zone VAV) Control | 41 | | |
| Variable Air Volume Applications (Traditional VAV) | 43 | | |
| Constant Volume or Variable Air Volume Applications (SZVAV or Traditional) | 46 | | |
| Maintenance | 48 | | |
| Troubleshooting | 51 | | |
| ReliaTel Controls | 51 | | |
| System Status Checkout Procedure | 51 | | |
| Resetting Cooling and Heating Lockouts . | 52 | | |
| Zone Temperature Sensor (ZTS) Service Indicator | 53 | | |
| Clogged Filter Switch | 53 | | |

Model Number Description

Digit 1 – Unit Type

W = Packaged Cooling, Electric Heat

Digit 2 – Efficiency

S = Standard Efficiency

Digit 3 – Airflow Configuration

D = Downflow

H = Horizontal

Digit 4, 5, 6 – Nominal Gross Cooling Capacity (MBh)

150 = 12½ Tons, 60Hz

155 = 15 Tons, 50Hz

180 = 15 Tons, 60Hz

200 = 20 Ton, 50Hz

240 = 20 Tons, 60Hz

Digit 7 – Major Design Sequence

E = R-410A Refrigerant

Digit 8 – Voltage Selection

3 = 208-230/60/3

4 = 460/60/3

W = 575/60/3

T = 200/50/1

D = 380-415/50/3

Digit 9 – Unit Controls

R = Reliatel

Digit 10 – Heating Capacity

Note: (Applicable to Digit 1 W models only)

0 = No Heat

G = 18 kW Electric Heat

N = 36 kW Electric Heat

P = 54 kW Electric Heat

R = 72 kW Electric Heat

Digit 11 – Minor Design Sequence

Digit 12, 13 – Service Sequence

Digit 14 – Fresh Air Selection

0 = No Fresh Air

D = Econ Dry Bulb w/ Barometric Relief¹

F = Econ Reference Enthalpy w/ Barometric Relief¹

H = Econ Comparative Enthalpy w/ Barometric Relief¹

K = Low Leak Econ w/ Barometric Relief¹

M = Low Leak Econ Reference Enthalpy w/ Barometric Relief¹

P = Low Leak Econ Comparative Enthalpy w/ Barometric Relief¹

Digit 15 – Supply Fan/Drive Type/Motor

0 = Standard Motor

1 = Oversized Motor²

3 = High Efficiency Motor²

6 = Single Zone Variable Air Volume Standard Motor

7 = Multi-Speed Standard Motor

8 = Single Zone Variable Air Volume Oversized Motor

9 = Multi-Speed Oversized Motor

A = Single Zone Variable Air Volume Standard Motor w/ Shaft Ground Ring

B = Multi-Speed Standard Motor w/ Shaft Ground Ring

C = Single Zone Variable Air Volume Oversized Motor w/ Shaft Ground Ring

D = Multi-Speed Oversized Motor w/ Shaft Ground Ring

Digit 16 – Hinged Service Access / Filters

0 = Standard Panels/Standard Filters¹³

A = Hinged Access/Standard Filters¹³

B = Standard Panels / 2" MERV 8 Filters²

C = Hinged Access / 2" MERV 8 Filters²

D = Standard Panels / MERV 13 Filters²

E = Hinged Access / MERV 13 Filters²

Digit 17 – Condenser Coil Protection

0 = Standard Coil

1 = Standard Coil With Hail Guard

2 = Black Epoxy Pre-Coated Coil

3 = Black Epoxy Pre-Coated Coil with Hail Guard

Digit 18 – Through The Base Provisions

0 = No Through The Base Provisions

A = Through The Base Electric³

D = Through The Base Utilities Access

Digit 19 – Disconnect Switch/Circuit Breaker⁴

0 = No Disconnect/circuit break

1 = Unit Mounted Non-Fused Disconnect Switch

2 = Unit Mounted Circuit Breaker

Digit 20 – Convenience Outlet Option

0 = Without Convenience Outlet

A = Unpowered Convenience Outlet⁵

B = Powered Convenience Outlet⁵

Digit 21 – Communications Options

0 = Without Communications Options

1 = Trane Communications Interface

2 = Lontalk Communications Interface

6 = Building Automation Control Network Communications Interface

7 = Air-Fi™ Wireless Communications¹⁵

Digit 22 – Refrigeration System Option

0 = Standard refrigeration system

Digit 23 – Refrigeration Controls

0 = Without Refrigeration Controls

1 = Frostat⁶

Digit 24 – Smoke Detector^{7, 8}

0 = Without Smoke Detector

A = Return Air Smoke Detector

B = Supply Air Smoke Detector

C = Return/Supply Air Smoke Detector

D = Plenum Smoke Detector⁹

Digit 25 – System Monitoring Controls⁶

0 = No Monitoring Controls

1 = Clogged Filter Switch

2 = Fan Failure Switch

3 = Discharge Air Sensing

4 = Clogged Filter Switch and Fan Failure

5 = Clogged Switch and Discharge Air

Sensing

6 = Fan Failure Switch and Discharge Air Sensing

7 = Clogged Filter Switch, Fan Failure Switch and Discharge Air Sensing

A = Condensate Drain Pan Overflow Switch

B = Clogged Filter Switch and Condensate Drain Pan Overflow Switch

C = Fan Failure Switch and Condensate Drain Pan Overflow Switch

D = Discharge Air Sensing and Condensate Drain Pan Overflow Switch

E = Clogged Filter Switch, Fan Failure

Switch and Condensate Drain Pan Overflow Switch

F = Clogged Filter Switch, Discharge Air Sensing Tube and Condensate Drain Pan Overflow Switch

G = Fan Failure Switch, Discharge Air Sensing Tube and Condensate Drain Pan Overflow Switch

H = Clogged Filter Switch, Fan Failure Switch, Discharge Air Sensing and Condensate Drain Pan Overflow Switch

Digit 26 - System Monitoring Controls

0 = No Monitoring Controls

A = Demand Control Ventilation (CO₂)¹⁰

B = FDD (Fault Detection and Diagnostics)

Model Number Description

C = FDD (Fault Detection Diagnostics) & Demand Control Ventilation (CO₂)¹⁰

Digit 27 - Unit Hardware Enhancements

0 = No Enhancements
1 = Stainless Steel Drain Pan

Digit 28 - Short Circuit Current Rating

0 = Standard SCCR
A = 65kA SCCR Option^{11, 12}

Digit 31 - Advanced Unit Controls

0 = Standard Unit Controls
1 = Human Interface¹⁴

Note: Most Factory Installed Options available for Downflow Air Discharge units only. Please verify with ordering system for availability.

Model Number Notes

1. Some field set up required.
2. Available factory installed on downflow AND horizontal units. Verify with ordering system.
3. Through-the-base electrical option or Horizontal-Side Access must be ordered with either unit mounted disconnect or circuit breaker.
4. Unit mounted disconnect and circuit breakers are mutually exclusive of each other.
5. Must be ordered with Through-the-Base Electrical option or Horizontal-Side Access and either Unit Mounted Disconnect or Circuit Breaker.
6. ReliaTel Options Module is required when ordering the following accessories: Clogged Filter Switch, Fan Fail Switch, Condensate Overflow Switch, Discharge Air Sensing Kit, Froststat, Ventilation Override, Smoke Detector, Dehumidification and Modulating Gas Heat Furnace.
7. Requires ReliaTel Options Module.
8. Option cannot be ordered in conjunction with field installed economizer on downflow units. Must be factory installed. The return air smoke detector may not fit up or work properly on the Voyager units when used in conjunction with 3rd party accessories (such as bolt on heat wheels, economizers, and power exhaust). Do not order the return air smoke detectors when using this type of accessory.
9. Supply and/or return smoke detector may not be used with the plenum smoke detector.
10. Demand Control Ventilation Option includes wiring only. The CO₂ sensor is a field-installed only option.
11. Only available where MOP is above 60A.
12. 575 VAC option is 25kA.
13. Standard filters are not available with Low Leak Economizers.
14. Human Interface is standard with FDD (Fault Detection Diagnostics).
15. Must be used with BACnet™ open protocol.

General Information

Overview of Manual

Note: One copy of this document ships inside the control panel of each unit and is customer property. It must be retained by the unit's maintenance personnel.

This booklet describes proper installation, operation, and maintenance procedures for air cooled systems.

By carefully reviewing the information within this manual and following the instructions, the risk of improper operation and/or component damage will be minimized.

It is important that periodic maintenance be performed to help assure trouble free operation. A maintenance schedule is provided at the end of this manual.

Should equipment failure occur, contact a qualified service organization with qualified, experienced HVAC technicians to properly diagnose and repair this equipment.

Unit Inspection

As soon as the unit arrives at the job site:

- Verify that the nameplate data matches the data on the sales order and bill of lading (including electrical data).
- Verify that the power supply complies with the unit nameplate specifications.
- Visually inspect the exterior of the unit, including the roof, for signs of shipping damage.
- Visually inspect the internal components for shipping damage as soon as possible after delivery and before it is stored. Do not walk on the sheet metal base pans.
- If concealed damage is discovered, notify the carrier's terminal of damage immediately by phone and by mail. Concealed damage must be reported within 15 days.

Request an immediate joint inspection of the damage by the carrier and the consignee. Do not remove damaged material from the receiving location. Take photos of the damage, if possible. The owner must provide reasonable evidence that the damage did not occur after delivery.

- Notify the appropriate sales representative before installing or repairing a damaged unit.

⚠ WARNING

Fiberglass Wool!

Product contains fiberglass wool. Disturbing the insulation in this product during installation, maintenance or repair will expose you to airborne particles of glass wool fibers and ceramic fibers known to the state of California to cause cancer through inhalation. You MUST wear all necessary Personal Protective Equipment (PPE) including gloves, eye protection, mask, long sleeves and pants when working with products containing fiberglass wool. Exposure to glass wool fibers without all necessary PPE equipment could result in cancer, respiratory, skin or eye irritation, which could result in death or serious injury.

Precautionary Measures

- Avoid breathing fiberglass dust.
- Use a NIOSH approved dust/mist respirator.
- Avoid contact with the skin or eyes. Wear long-sleeved, loose-fitting clothing, gloves, and eye protection.
- Wash clothes separately from other clothing: rinse washer thoroughly.
- Operations such as sawing, blowing, tear-out, and spraying may generate fiber concentrations requiring additional respiratory protection. Use the appropriate NIOSH approved respiration in these situations.

First Aid Measures

- Eye Contact - Flush eyes with water to remove dust. If symptoms persist, seek medical attention.
- Skin Contact - Wash affected areas gently with soap and warm water after handling.

Storage

Take precautions to prevent condensate from forming inside the unit's electrical compartments and motors if:

16. The unit is stored before it is installed; or,
17. The unit is set on the roof curb, and temporary heat is provided in the building. Isolate all side panel service entrances and base pan openings (e.g., conduit holes, S/A and R/A openings, and flue openings) from the ambient air until the unit is ready for start-up.

Note: Do not use the unit's heater for temporary heat without first completing the start-up procedure detailed under "Start Up," p. 35.

The manufacturer will not assume any responsibility for equipment damage resulting from condensate accumulation on the unit's electrical and/or mechanical components.

General Information

Unit Clearances

Figure 1, p. 12 illustrates the minimum operating and service clearances for either a single or multiple unit installation. These clearances are the minimum distances necessary to assure adequate serviceability, cataloged unit capacity, and peak operating efficiency.

Providing less than the recommended clearances may result in condenser coil starvation, “short-circuiting” of exhaust and economizer airflows, or recirculation of hot condenser air.

Unit Description

Before shipment, each unit is leak tested, dehydrated, charged with refrigerant and compressor oil, and run tested for proper control operation.

The condenser coils are aluminum fin, mechanically bonded to copper tubing.

Direct-drive, vertical discharge condenser fans are provided with built-in thermal overload protection.

The ReliaTel™ Control Module is a microelectronic control system that is referred to as “Refrigeration Module” (RTRM). The acronym RTRM is used extensively throughout this document when referring to the control system network.

This module through Proportional/Integral control algorithms perform specific unit functions that governs unit operation in response to; zone temperature, supply air temperature, and/or humidity conditions depending on the application. The stages of capacity control for these units are achieved by starting and stopping the compressors.

The RTRM is mounted in the control panel and is factory wired to the respective internal components. The RTRM receives and interprets information from other unit modules, sensors, remote panels, and customer binary contacts to satisfy the applicable request for cooling.

ReliaTel™ Control

Economizer Control Actuator

The ECA monitors the mixed air temperature, return air temperature, minimum position setpoint (local or remote), power exhaust setpoint, CO2 setpoint, CO2, and ambient dry bulb/enthalpy sensor or comparative humidity (return air humidity against ambient humidity) sensors, if selected, to control dampers to an accuracy of +/- 5% of stroke. The actuator is spring returned to the closed position any time that power is lost to the unit. It is capable of delivering up to 25 inch pounds of torque and is powered by 24 Vac.

RTCI – ReliaTel™ Trane Communication Interface (Optional)

This module is used when the application calls for an ICS™ building management type control system. It allows the control and monitoring of the system through an ICS panel. The module can be ordered from the factory or ordered as a kit to be field installed. Follow the installation instruction that ships with each kit when field installation is necessary.

RLCI – ReliaTel™ LonTalk Communication Interface (Optional)

This module is used when the application calls for an ICS™ building management type control system that is LonTalk. It allows the control and monitoring of the system through an ICS panel. The module can be ordered from the factory or ordered as a kit to be field installed. Follow the installation instruction that ships with each kit when field installation is necessary.

RTOM – ReliaTel™ Options Module (Optional)

The RTOM monitors the supply fan proving, clogged filter, supply air temperature, exhaust fan setpoint, supply air tempering, Froststat™ and smoke detector. Refer to system input devices and functions for operation.

WCI – Trane Air-Fi™ Wireless Communication Interface (Optional)

The Trane Air-Fi Communication Interface allows for wireless communication between system controls, unit controls, and wireless sensors for Trane control products that use BACnet protocol. The WCI replaces the need for communications wire in all system applications.

System Input Devices and Functions

The RTRM must have a zone sensor or thermostat input in order to operate the unit. The flexibility of having several mode capabilities depends upon the type of zone sensor or thermostat selected to interface with the RTRM.

The descriptions of the following basic Input Devices used within the RTRM network are to acquaint the operator with their function as they interface with the various modules. Refer to the unit’s electrical schematics for the specific module connections.

Note: *The following controls are available from the factory for field installation.*

Supply Fan Failure Input (Optional)

The Fan Failure Switch can be connected to sense indoor fan operation:

FFS (Fan Failure Switch) If air flow through the unit is not proven by the differential pressure switch connected to

the RTOM (factory set point 0.07 " w.c.) within 40 seconds nominally, the RTRM will shut off all mechanical operations, lock the system out, send a diagnostic to ICS, and the SERVICE output will flash. The system will remain locked out until a reset is initiated either manually or through ICS.

Drain Pan Condensate Overflow Switch (Optional)

This input incorporates the Condensate Overflow Switch (COF) mounted on the drain pan and the ReliaTel Options Module (RTOM). When the condensate level reaches the trip point for 6 continuous seconds, the RTOM will shut down all unit function until the overflow condition has cleared. The unit will return to normal operation after 6 continuous seconds with the COF in a non-tripped condition. If the condensate level causes the unit to shutdown more than 2 times in a 3 day period, the unit will be locked-out of operation. A manual reset of the diagnostic system through the Zone Sensor or Building Automation System (BAS) will be required. Cycling unit power will also clear the fault."

Clogged Filter Switch (Optional)

The unit mounted clogged filter switch monitors the pressure differential across the return air filters. It is mounted in the filter section and is connected to the RTOM. A diagnostic SERVICE signal is sent to the remote panel if the pressure differential across the filters is at least 0.5" w.c. The contacts will automatically open when the pressure differential across the filters decreases to approximately 0.4" w.c. The clogged filter output is energized when the supply fan is operating and the clogged filter switch has been closed for at least 2 minutes. The system will continue to operate regardless of the status of the filter switch.

Please note that on units equipped with factory installed MERV 13 filters, a clogged filter switch with different pressure settings will be installed. This switch will close when the differential pressure is approximately 0.8' w.c. and open when the differential falls to 0.7" w.c.

Compressor Disable (CPR1/2)

This input incorporates the low pressure control (LPC) of each refrigeration circuit and can be activated by opening a field supplied contact installed on the LTB.

If this circuit is open before the compressor is started, the compressor will not be allowed to operate. Anytime this circuit is opened for 1 continuous second during compressor operation, the compressor for that circuit is immediately turned "Off". The compressor will not be allowed to restart for a minimum of 3 minutes should the contacts close.

If four consecutive open conditions occur during the first three minutes of operation, the compressor for that circuit will be locked out, a diagnostic communicated to the remote panel (if installed), and a manual reset will be required to restart the compressor.

Low Pressure Control

ReliaTel Control

When the LPC is opened for 1 continuous second, the compressor for that circuit is turned off immediately. The compressor will not be allowed to restart for a minimum of 3 minutes.

If four consecutive open conditions occur during the first three minutes of operation, the compressor will be locked out, a diagnostic communicated to ICS™ if applicable, and a manual reset will be required to restart the compressor.

High Pressure Control (Optional)

ReliaTel Control

The high pressure controls are wired in series between the compressor outputs on the RTRM and the compressor contactor coils. If the high pressure control switch opens, the RTRM senses a lack of current while calling for cooling and locks the compressor out.

On dual circuit units, if the high pressure control opens, the compressor on the affected circuit is locked out. A manual reset for the affected circuit is required.

Power Exhaust Control (Optional)

The power exhaust fan is started whenever the position of the economizer dampers meets or exceed the power exhaust setpoint when the indoor fan is on.

The setpoint panel is located in the return air section and is factory set at 25%.

Lead/Lag Control (Dual Circuit Only)

Lead/Lag is a selectable input located on the RTRM. The RTRM is configured from the factory with the Lead/Lag control disabled. To activate the Lead/Lag function, simply cut the wire connected to J3-8 at the RTRM. When it is activated, each time the designated lead compressor is shut off due to the load being satisfied, the lead compressor or refrigeration circuit switches. When the RTRM is powered up, i.e. after a power failure, the control will default to the number one circuit compressor.

Evaporator Frost Control

This input incorporates the Frostat™ control (FOS) mounted in the indoor coil and can be activated by closing a field supplied contact installed in parallel with the FOS. If this circuit is closed before the compressor is started, the compressor will not be allowed to operate. Anytime this circuit is closed for 1 continuous second during compressor operation, the compressor for that circuit is immediately turned "Off". The compressor will not be allowed to restart for a minimum of 3 minutes should the FOS open.

Smoke Detector Sensor (Optional)

This sensor is only applicable on units equipped with a RTOM. It provides high limit "shutdown" of the unit and

General Information

requires a manual reset. The sensor is used to detect smoke due to fire in the air conditioning or ventilation ducts.

The supply and return air smoke detectors are designed to shut off the unit if smoke is sensed in the supply air stream or return air stream. This function is performed by sampling the airflow entering the unit at the return air opening. Follow the instructions provided below to assure that the airflow through the unit is sufficient for adequate sampling. Failure to follow these instructions will prevent the smoke detectors from performing it's design function.

Important: *Airflow through the unit is affected by the amount of dirt and debris accumulated on the indoor coil and filters. To insure that airflow through the unit is adequate for proper sampling by the return air smoke detector, complete adherence to the maintenance procedures, including recommended intervals between filter changes, and coil cleaning is required.*

Periodic checks and maintenance procedures must be performed on the smoke detector to insure that it will function properly. For detailed instructions concerning these checks and procedures, refer to the appropriate section(s) of the smoke detector Installation and Maintenance Instructions provided with the literature package for this unit.

In order for the supply air smoke detector or return air smoke detector to properly sense smoke in the supply air stream or return air stream, the air velocity entering the smoke detector unit must be between 500 and 4000 feet per minute. Equipment covered in this manual will develop an airflow velocity that falls within these limits over the entire airflow range specified in the evaporator fan performance tables.

Zone Sensors

Note: *Zone sensor required for units configured for Single Zone VAV indoor fan system control to enable Single Zone VAV functionality.*

Zone Sensor Module (ZSM) (BAYSENS107*)

This electronic sensor features three system switch settings (Heat, Cool, and Off) and two fan settings (On and Auto). It is a manual changeover control with single setpoint. (Cooling Setpoint Only)

Zone Sensor (BAYSENS109*)

This electronic sensor features four system switch settings (Heat, Cool, Auto, and Off) and two fan settings (On and Auto) with four system status LED's. It is a manual or auto changeover control with dual setpoint capability. It can be used with a remote zone temperature sensor BAYSENS075*.

Programmable Zone Sensor (BAYSENS119*)

Programmable Night Setback: Auto or manual changeover with seven-day programming. Keyboard selection of Heat, Cool, Fan, Auto, or On. All programmable sensors have System On, Heat, Cool, Service LED/indicators as standard. Night Setback Sensors have one (1) Occupied, one (1) Un-occupied, and one (1) Override program per day.

Remote Zone Sensor (BAYSENS073*)

This electronic sensor features remote zone sensing and timed override with override cancellation. It is used with a Trane Integrated Comfort™ building management system.

Remote Zone Sensor (BAYSENS074*)

This electronic sensor features single setpoint capability and timed override with override cancellation. It is used with a Trane Integrated Comfort™ building management system.

Remote Zone Sensor (BAYSENS016*)

This bullet type temperature sensor can be used for; outside air (ambient) sensing, return air temperature sensing, supply air temperature sensing, remote temperature sensing (uncovered). Wiring procedures vary according to the particular application and equipment involved. Refer to the unit's wiring diagrams for proper connections.

Remote Zone Sensor (BAYSENS075*)

This electronic sensor can be used with BAYSENS106*, 108*, 110*, 109* Remote Panels. When this sensor is wired to a BAYSENS109* Remote Panel, wiring must be 18 AWG Shielded Twisted Pair (Belden 8760 or equivalent). Refer to the specific Remote Panel for wiring details.

Wireless Zone Sensor (BAYSENS050)

This electronic sensor features five system settings (Auto, Off, Cool, Heat, and Emergency Heat) and with On and Auto fan settings. It is a manual or auto changeover control with dual setpoint capability. Other features include a timed override function, lockable system settings, and Fahrenheit or Celsius temperature display. Included with the wireless zone sensor will be a receiver that is to be mounted inside the unit, a mounting bracket, and a wire harness.

Thermostat (BAYSTAT150)

This thermostat is a multi-stage 3 heat/2 cool, auto-changeover digital display thermostat. It is a programmable thermostat, and a 7-day programmable stat with night setback shall be available. In addition, it is wall mounted.

Thermostat (BAYSTAT151)

This thermostat is a single-stage 1 heat/1 cool, auto-changeover digital display thermostat. It is a non-programmable, wall-mounted thermostat.

Thermostat (BAYSTAT155)

This thermostat is a multi-stage 3 heat/2 cool, auto changeover digital display thermostat. It is a non-programmable, wall-mounted thermostat, and it can be used for Economizer Operation.

Human Interface - 5 Inch Color Touchscreen (Optional)

The 5 inch Color Touchscreen Human Interface provides an intuitive user interface to the rooftop unit that speeds up unit commissioning, shortens unit troubleshooting times, and enhances preventative maintenance measures. The human interface includes several features including:

- Data trending capabilities by means of time series graphs
- Historical alarm messages
- Real-time sensor measurements
- On board system setpoints
- USB port that enables the downloading of component runtime information as well as trended historical sensor data
- Customized reports

Unit Dimensions

Figure 1. Typical installation clearances for single & multiple unit applications

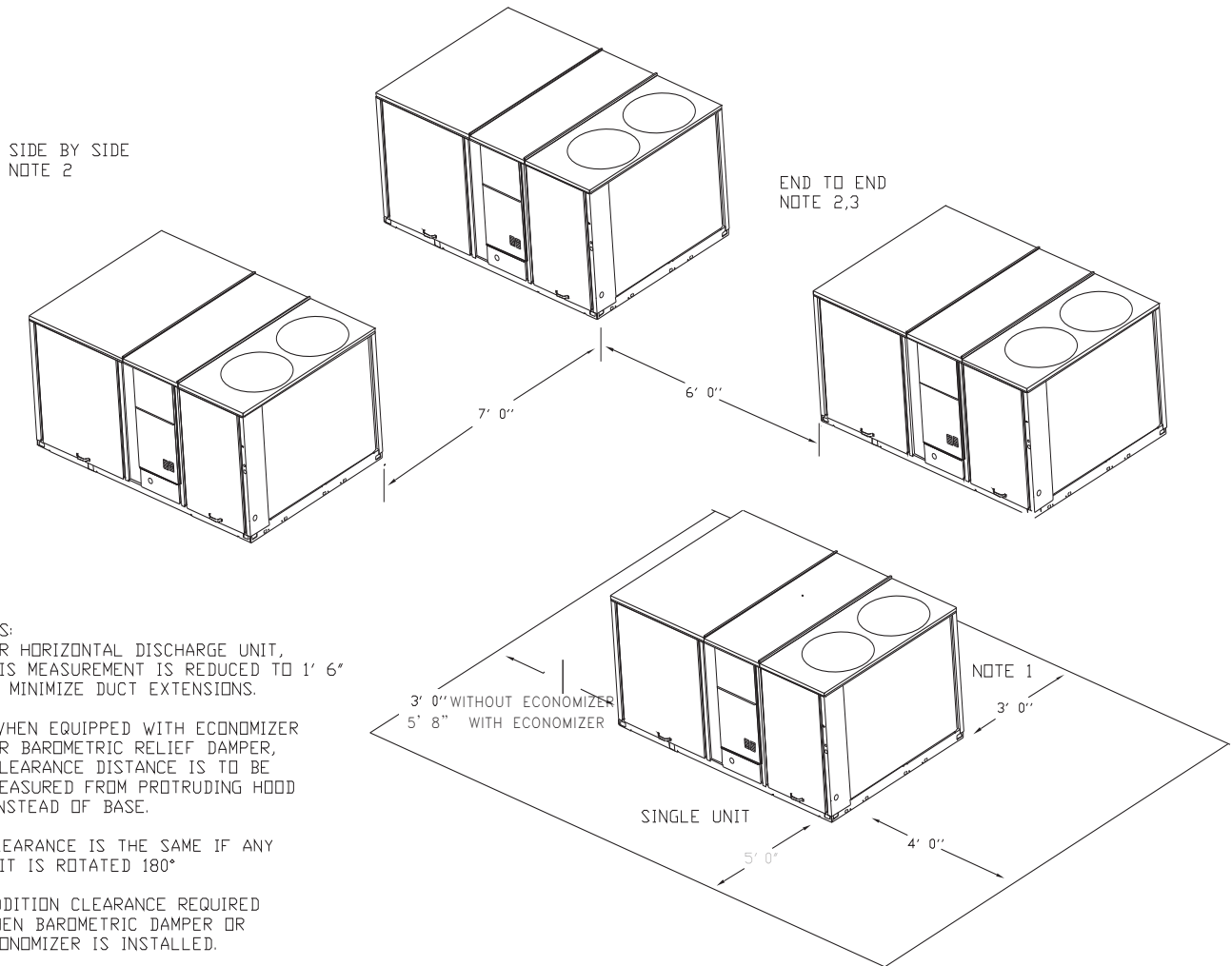
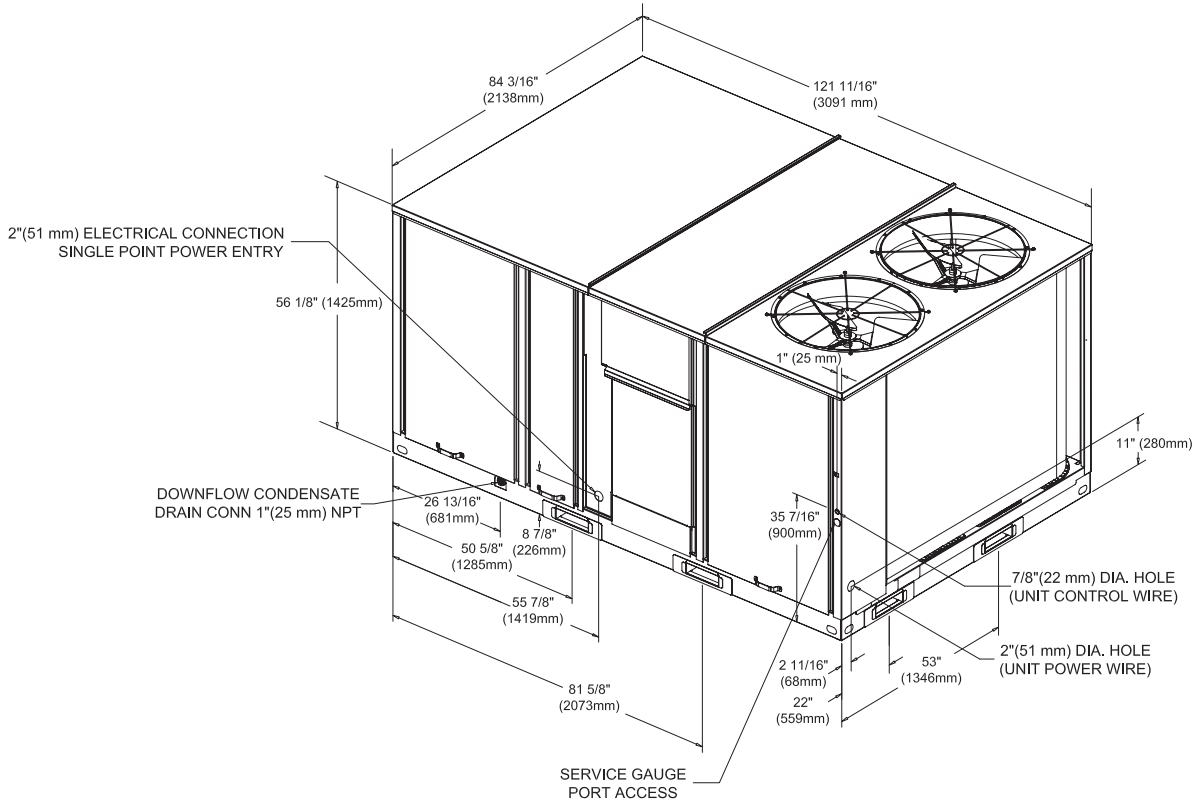
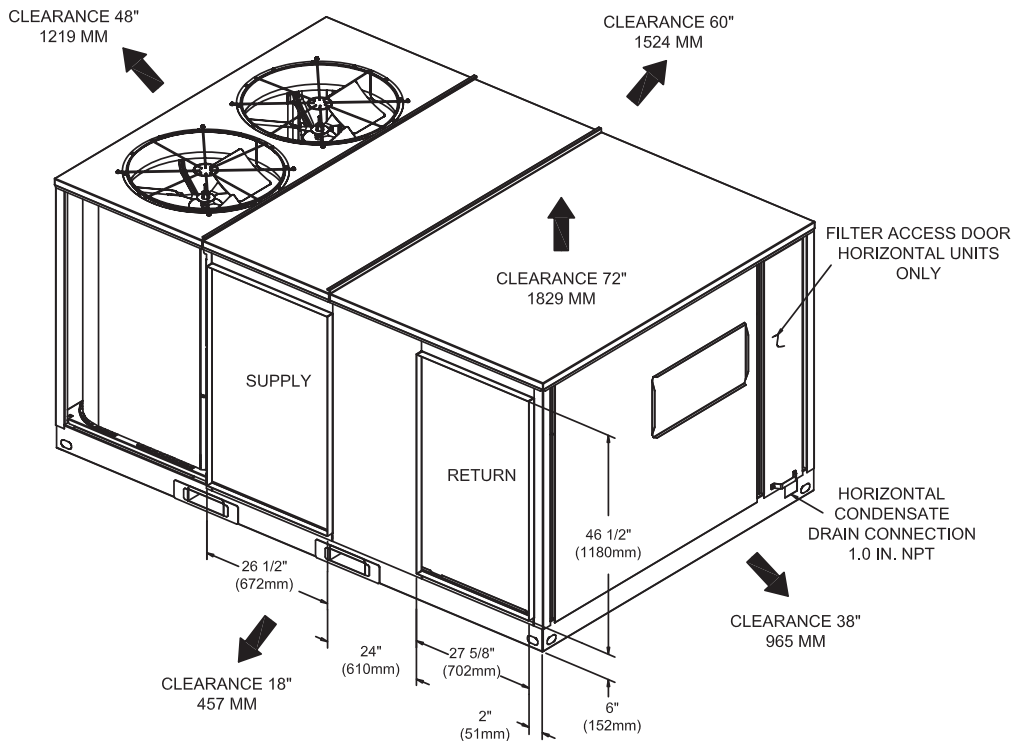

Figure 2. Heat pump models - 12½ - 15 tons



* All dimensions are in inches/millimeters.

Figure 3. Horizontal duct dimensional data heat pump models - 12½ - 20 tons



* All dimensions are in inches/millimeters.

Unit Dimensions

Figure 4. Heat pump models - 12½ - 15 tons

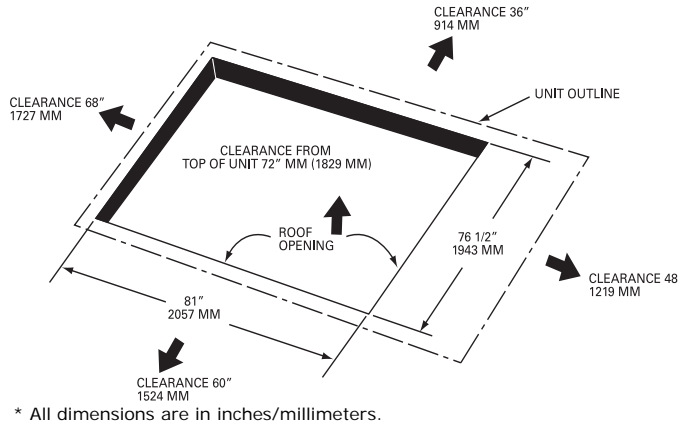

Figure 5. Heat pump models - 12½ - 15 tons

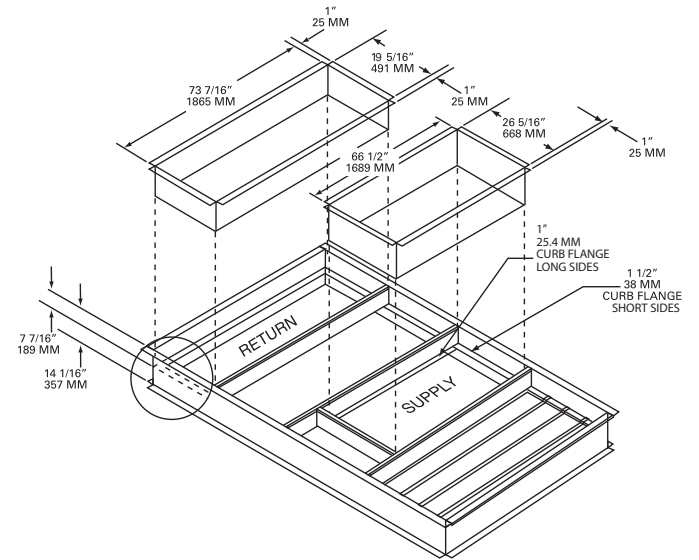

Figure 6. Heat pump models - 12½ - 15 tons

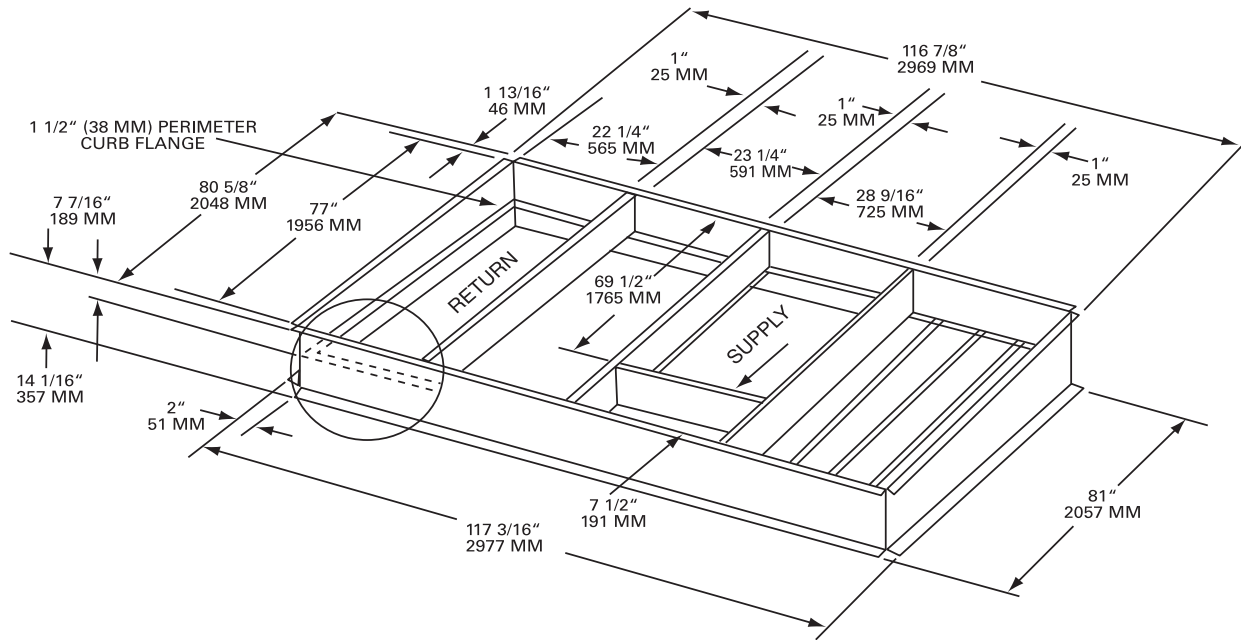
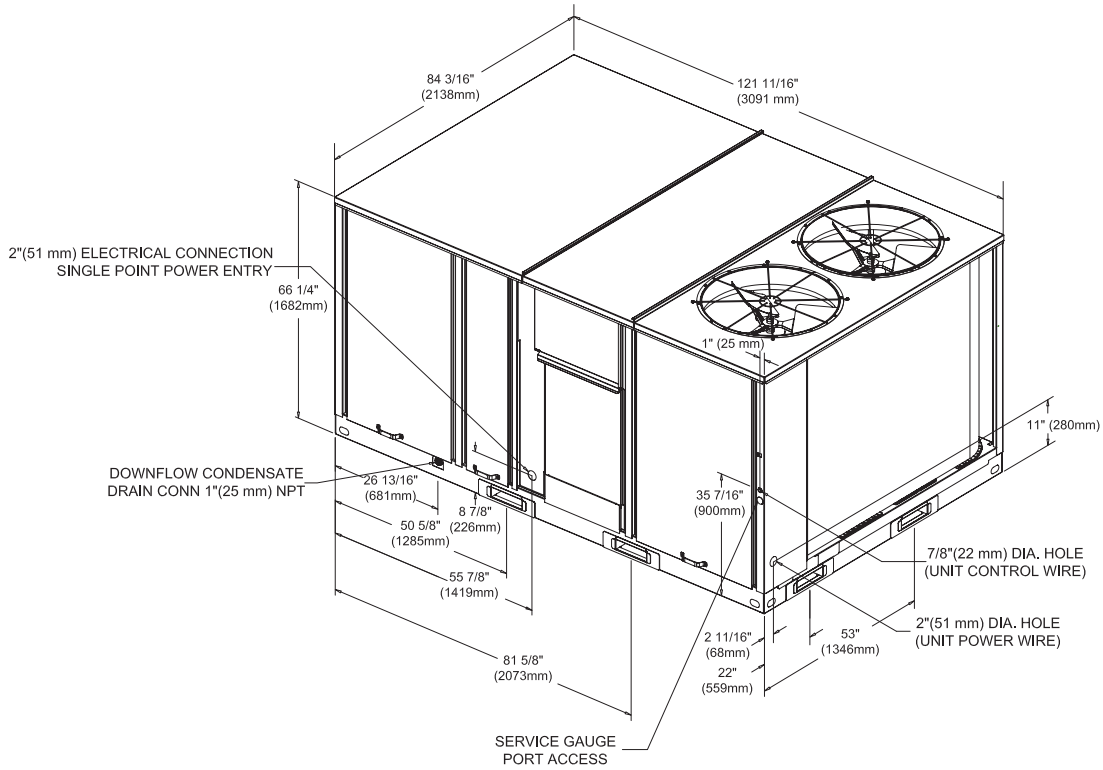
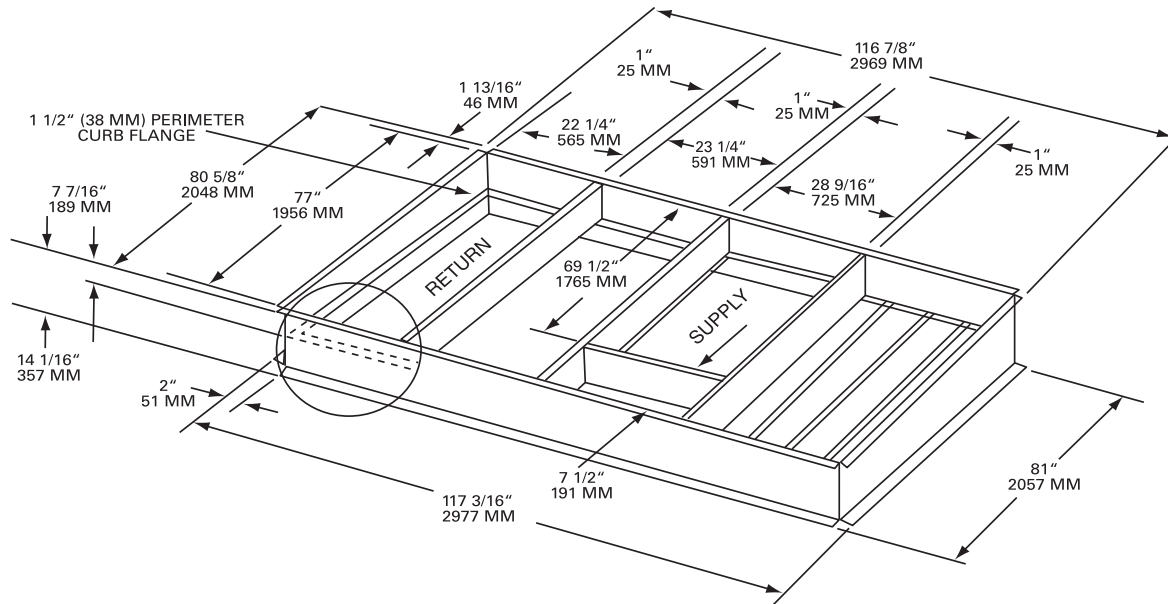

Figure 7. Heat pump models - 20 tons



* All dimensions are in inches/millimeters.

Figure 8. Heat pump models - 20 tons



* All dimensions are in inches/millimeters.

Unit Dimensions

Figure 9. Heat pump models - 20 tons

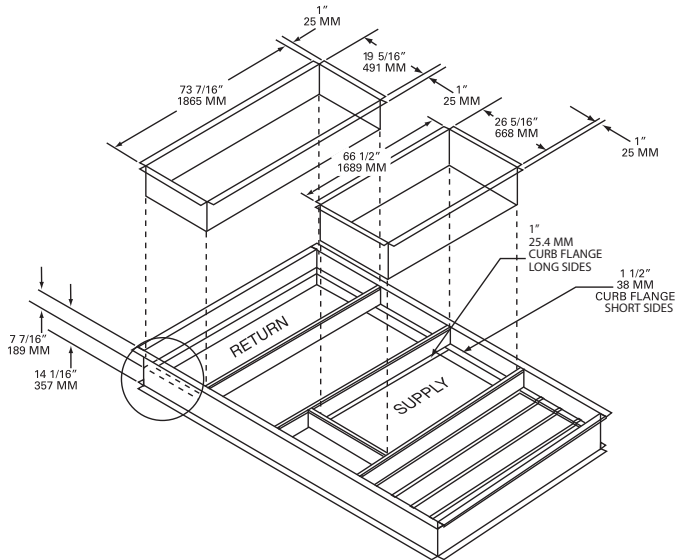

* Duct flanges mount 7-7/16" down inside the curb on the 1-1/2" curb flanges.
 Roofcurb is intended for downflow use only.
 * All dimensions are in inches/millimeters.

Figure 10. Heat pump models - 20 tons

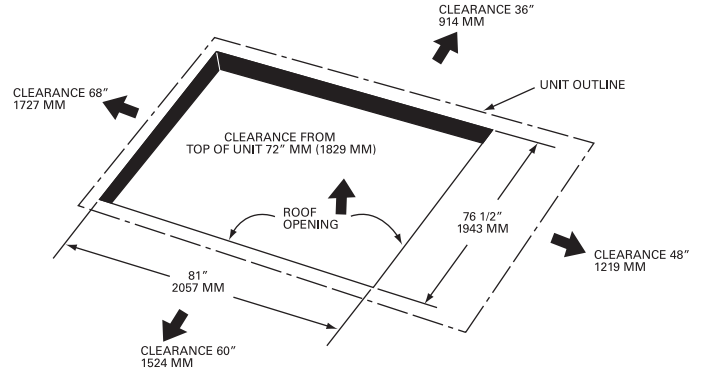

* All dimensions are in inches/millimeters.

Figure 11. Downflow & horizontal condensate locations

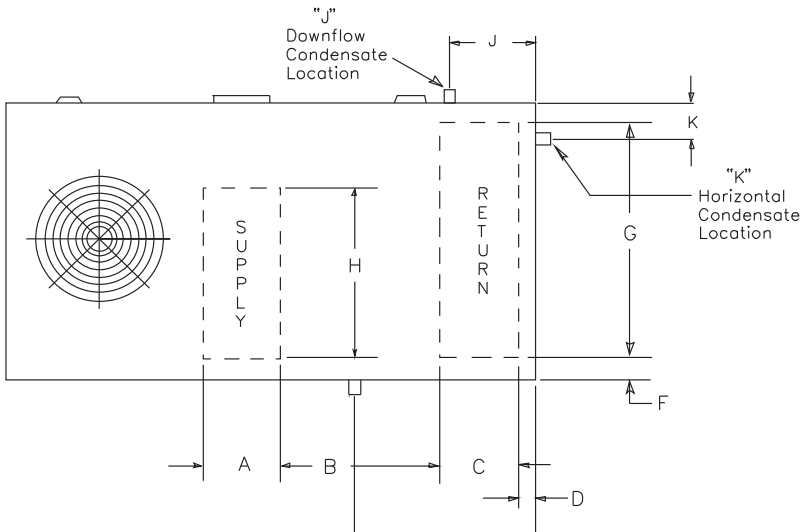

Table 1. Unit dimensions

| Tons | Downflow Only | | | | | | | Condensate Drain Size | Condensate Drain Location | | | |
|-------------|---------------|--------|----------|-------|-------|---------|----------|-----------------------|---------------------------|--------|------------|-------|
| | | | | | | | | | Downflow | | Horizontal | |
| | A | B | C | D | F | G | H | | E | J | E | K |
| 12½, 15, 20 | 26 7/16 | 28 3/4 | 19 15/16 | 4 1/4 | 4 1/4 | 76 5/16 | 68 11/16 | 1 NPT | - | 26 3/4 | - | 5 3/8 |

Figure 12. Through the base utility locations and access panel swing clearances

TOP VIEW SHOWING THROUGH THE BASE
ELECTRICAL UTILITY LOCATIONS AND ACCESS PANEL SWING CLEARANCES.

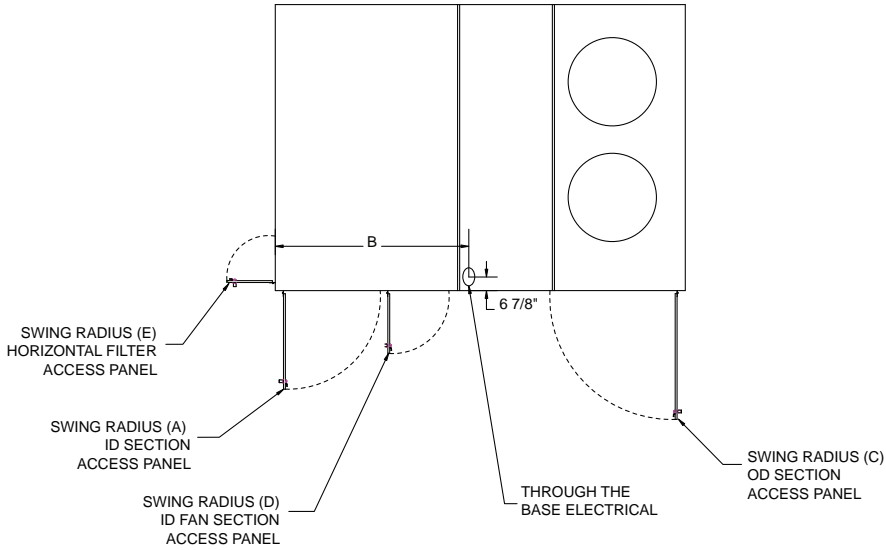

Table 2. Swing clearances

| Unit Model # | A | B | C | D | E |
|--------------|--------|--------|--------|--------|-----|
| WSD150-180 | 42 3/8 | 48 3/8 | 31 | N/A | N/A |
| WSD240 | 29 1/2 | 56 | 38 1/2 | 18 1/2 | N/A |
| WSH150-180 | 42 3/8 | N/A | 31 | N/A | 12 |
| WSH240 | 29 1/2 | N/A | 38 1/2 | 18 1/2 | 14 |

Note: All dimensions are in inches.

Unit Weights

Table 3. Typical unit weights and point loading data

| Unit Description | Net Weight | Corner Weights (lbs.) | | | | Center of Gravity (in.) | |
|------------------|------------|-----------------------|-----|-----|-----|-------------------------|-------|
| | | A | B | C | D | Length | Width |
| WS*150 | 2024 | 647 | 524 | 385 | 468 | 55 | 35 |
| WS*155 | 2028 | 648 | 525 | 386 | 469 | 55 | 35 |
| WS*180 | 2028 | 648 | 525 | 386 | 469 | 55 | 35 |
| WS*200 | 2198 | 717 | 575 | 403 | 502 | 54 | 35 |
| WS*240 | 2198 | 717 | 575 | 403 | 502 | 54 | 35 |

Note: Corner weights are given for information only. Unit is to be supported continuously by a curb or equivalent frame support.

Rigging

Refer to [Figure 13](#) and [Table 3](#) for typical unit operating weights rigging before proceeding.

⚠ WARNING

Heavy Objects!

Ensure that all the lifting equipment used is properly rated for the weight of the unit being lifted. Each of the cables (chains or slings), hooks, and shackles used to lift the unit must be capable of supporting the entire weight of the unit. Lifting cables (chains or slings) may not be of the same length. Adjust as necessary for even unit lift. Other lifting arrangements could cause equipment or property damage. Failure to follow instructions above or properly lift unit could result in unit dropping and possibly crushing operator/ technician which could result in death or serious injury.

⚠ WARNING

Improper Unit Lift!

Test lift unit approximately 24 inches to verify proper center of gravity lift point. To avoid dropping of unit, reposition lifting point if unit is not level. Failure to properly lift unit could result in unit dropping and possibly crushing operator/technician which could result in death or serious injury and possible equipment or property-only damage.

1. Remove the shipping crate from around the unit. Do not remove the crating from the top of the unit.
2. Rig the unit as shown in [Figure 13](#). Attach adequate strength lifting slings to all four lifting brackets in the unit base rail. Do not use cables, chains, or slings except as shown.
3. Install a lifting bar, as shown in [Figure 13](#), to protect the unit and to facilitate a uniform lift. The minimum distance between the lifting hook and the top of the unit should be 7 feet.

NOTICE

Unit Damage!

Unit damage will occur if fork lifting is attempted once the pallet has been removed.

4. Removal of the base pallet must be completed before unit can be set. Prior to lifting the unit, remove the 6 fork pockets from the base rails and 4 wood screws from the lifting lug corners. The unit will then separate from the pallet when lifted.
5. Test-lift the unit to ensure it is properly rigged and balanced, make any necessary rigging adjustments.
6. Lift the unit and position it into place.
7. Downflow units; align the base rail of the unit with the curb rail while lowering the unit onto the curb. Make sure that the gasket on the curb is not damaged while positioning the unit.

Figure 13. Rigging and center of gravity data

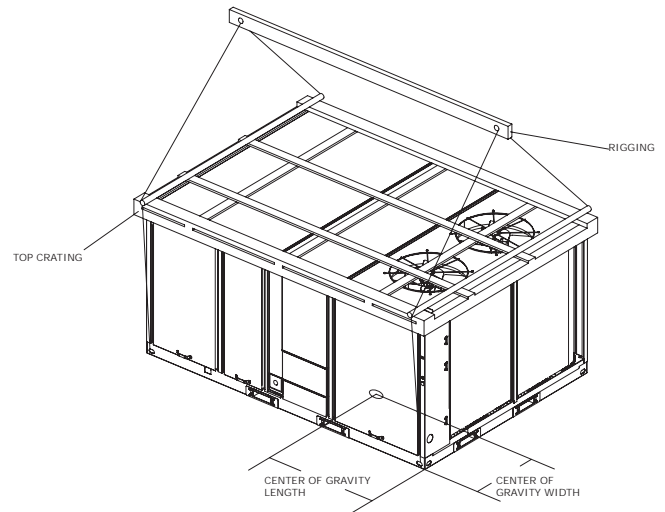

Installation

Foundation

NOTICE

Water Damage!

Non-factory penetrations through the base of this unit are not allowed. Any penetration in the base of the unit may affect the water tight integrity of the unit and lead to water leaks into the conditioned space. Failure to follow instructions could result in equipment and property damage.

Notes:

- For units with optional Condensate Overflow Switch (COF), the switch will not work properly if unit is not level or slightly sloped toward switch.
- To assure proper condensate flow during operation the unit and the curb must be level.

If the unit is installed at ground level, elevate it above the snow line. Provide concrete footings at each support location with a “full perimeter” support structure or a slab foundation for support. Refer to [Table 3, p. 18](#) for the unit’s operating and point loading weights when constructing a footing foundation.

If anchoring is required, anchor the unit to the slab using hold down bolts or isolators. Isolators should be installed to minimize the transmission of vibrations into the building.

For rooftop applications, ensure the roof is strong enough to support the combined unit and support structural weight.

⚠ WARNING

Risk of Roof Collapsing!

Confirm with a structural engineer that the roof structure is strong enough to support the combined weight of the roofcurb and the unit. Refer to [Table 3, p. 18](#) for typical unit and curb weights. Failure to ensure proper structural roof support could cause the roof to collapse, which could result in death or serious injury and property damage.

If anchoring is required, anchor the unit to the roof with hold-down bolts or isolators.

Check with a roofing contractor for proper waterproofing procedures.

Ductwork

Elbows with turning vanes or splitters are recommended to minimize air noise due to turbulence and to reduce static pressure.

When attaching the ductwork to the unit, provide a water-tight flexible connector at the unit to prevent operating sounds from transmitting through the ductwork.

All outdoor ductwork between the unit and the structure should be weather proofed after installation is completed.

Note: For sound consideration, cut only the holes in the roof deck for the ductwork penetrations. Do not cut out the entire roof deck within the curb perimeter.

If a Curb Accessory Kit is Not Used:

1. The ductwork can be attached directly to the factory-provided flanges around the unit’s supply and return air openings. Be sure to use flexible duct connections at the unit.
2. For “built-up” curbs supplied by others, gaskets must be installed around the curb perimeter flange and the supply and return air opening flanges.

General Unit Requirements

The checklist listed below is a summary of the steps required to successfully install a commercial unit. This checklist is intended to acquaint the installing personnel with what is required in the installation process. It does not replace the detailed instructions called out in the applicable sections of this manual.

- Check the unit for shipping damage and material shortage; file a freight claim and notify appropriate sales representative.
- Verify correct model, options and voltage from nameplate.
- Verify that the installation location of the unit will provide the required clearance for proper operation.
- Assemble and install the roof curb (if applicable). Refer to the latest edition of the curb installers guide that ships with each curb kit.
- Fabricate and install ductwork; secure ductwork to curb.
- Rigging the unit.
- Set the unit onto the curb; check for levelness.
- Ensure unit-to-curb seal is tight and without buckles or cracks.
- Install and connect a condensate drain line to the evaporator drain connection.

Factory Installed Economizer

- Ensure the standard economizer has been pulled out into the operating position. Refer to the economizer Installation Instructions for proper setup.

Note: Low Leak Economizers do not pull out. Refer to Low Leak Economizers Installation Instructions for proper setup.

- Install all access panels.

Installation

Electric Heat Requirements

- Verify that the power supply complies with the electric heater specifications on the unit and heater nameplate.
- Inspect the heater junction box and control panel; tighten any loose connections.
- Check electric heat circuits for continuity.

Condensate Drain Configuration

An evaporator condensate drain connection is provided on each unit. Refer to “Unit Dimensions,” p. 12 for the appropriate drain location.

A condensate trap must be installed at the unit due to the drain connection being on the “negative pressure” side of the fan. Install the P-Trap using the guidelines in Figure 14, p. 20.

A condensate drain line must be connected to the P-Trap. Pitch the drain lines at least 1/2 inch for every 10 feet of horizontal run to assure proper condensate flow. Do not allow the horizontal run to sag causing a possible double-trap condition which could result in condensate backup due to “air lock”.

Figure 14. Condensate trap installation

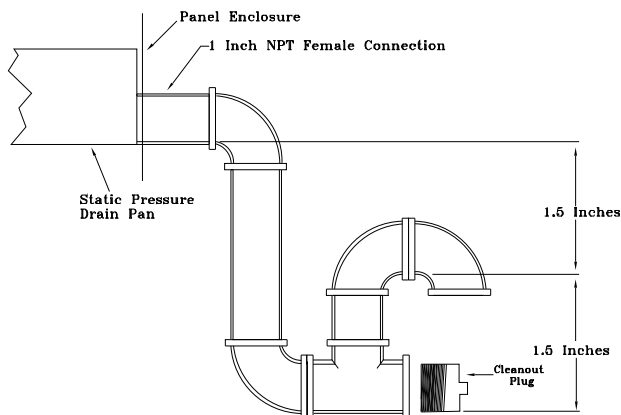

Filter Installation

Each unit ships with 2 inch filters installed. The quantity of filters is determined by unit size. Access to the filters is obtained by removing the indoor fan access panel. If included, filters are removed by pulling the filter removal tool.

Refer to the unit Service Facts (shipped with each unit) for filter requirements.

Note: Do not operate the unit without filters.

Electrical Requirements

⚠ WARNING

Proper Field Wiring and Grounding Required!

All field wiring **MUST** be performed by qualified personnel. Improperly installed and grounded field wiring poses **FIRE** and **ELECTROCUTION** hazards. To avoid these hazards, you **MUST** follow requirements for field wiring installation and grounding as described in **NEC** and your local/state electrical codes. Failure to follow code could result in death or serious injury.

Main Electrical Power Requirements

- Verify that the power supply complies with the unit nameplate specifications.
- Inspect all control panel components; tighten any loose connections.
- Connect properly sized and protected power supply wiring to a field-supplied/installed disconnect switch and to the main power terminal block (HTB1) in the unit control panel.

- Install proper grounding wires to an earth ground.

Note: All field-installed wiring must comply with **NEC** and applicable local codes.

Low Voltage Wiring (AC & DC) Requirements

- Install the zone thermostat, with or without switching subbase.
- Connect properly sized control wiring to the proper termination points between the zone thermostat and the unit control panel.

Field Installed Power Wiring

An overall dimensional layout for the standard field installed wiring entrance into the unit is illustrated in the [Unit Dimensions](#) section. To insure that the unit's supply power wiring is properly sized and installed, follow the guidelines outlined below.

Note: All field installed wiring must conform to **NEC** guidelines as well as **State and Local** codes.

Verify that the power supply available is compatible with the unit's nameplate ratings. The available supply power must be within 10% of the rated voltage stamped on the nameplate. Use only copper conductors to connect the power supply to the unit.

NOTICE

Use Copper Conductors Only!

Unit terminals are not designed to accept other types of conductors. Failure to use copper conductors could result in equipment damage.

Note: If the unit is not equipped with an optional factory installed nonfused disconnect switch or circuit breaker, a field supplied disconnect switch must be installed at or near the unit in accordance with the National Electrical Code (NEC latest edition).

Main Unit Power

⚠ WARNING

Proper Field Wiring and Grounding Required!

All field wiring **MUST** be performed by qualified personnel. Improperly installed and grounded field wiring poses **FIRE** and **ELECTROCUTION** hazards. To avoid these hazards, you **MUST** follow requirements for field wiring installation and grounding as described in **NEC** and your local/state electrical codes. Failure to follow code could result in death or serious injury.

Standard Wiring

The electrical service must be protected from over current and short circuit conditions in accordance with NEC requirements. Protection devices must be sized according to the electrical data on the nameplate.

1. If the unit is not equipped with an optional factory installed nonfused disconnect switch or circuit breaker, a field supplied disconnect switch must be installed at or near the unit in accordance with the National Electrical Code (NEC latest edition).
2. Location of the applicable electrical service entrance is illustrated in the [Unit Dimensions](#) section. Complete the unit's power wiring connections onto either; the main terminal block HTB1 inside the unit control panel, the factory mounted nonfused disconnect switch (UCD) or circuit breaker (UCB), or the electric heat terminal block. Refer to the customer connection diagram that shipped with the unit for specific termination points.
3. Provide proper grounding for the unit in accordance with local and national codes.

Optional TBUE Wiring (Through the Base Electrical Option)

1. Location of the applicable electrical service is illustrated in the following illustration. Refer to the customer connection diagram that is shipped with the unit for specific termination points. The termination points, depending on the customer option selected would be a factory mounted nonfused disconnect switch (UDC) or circuit breaker (UCB).
2. Provide proper grounding for the unit in accordance with local and national codes.

Figure 15. Through the base electrical option

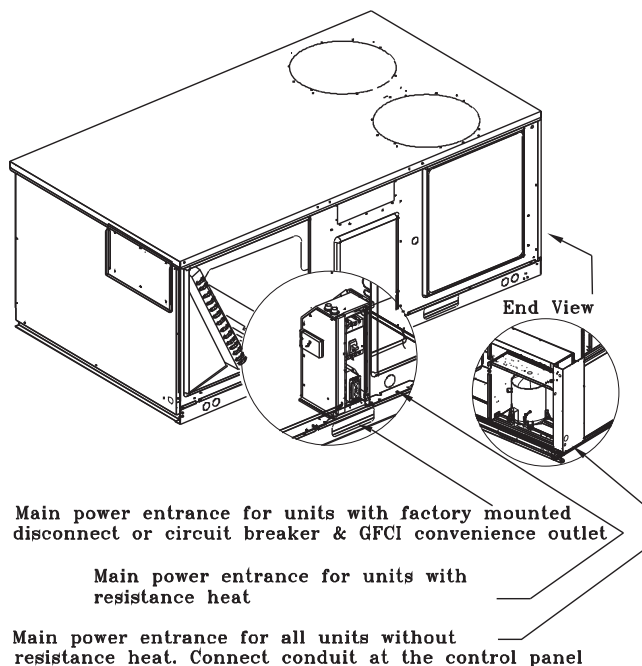

Field Installed Control Wiring

An overall layout of the various control options available with the required number of conductors for each control device is illustrated in [Figure 17, p. 23](#).

Note: All field wiring must conform to NEC guidelines as well as state and local codes.

Control Power Transformer

The 24 volt control power transformers are to be used only with the accessories called out in this manual. Transformers rated greater than 50 Vac are equipped with internal circuit breakers. If a circuit breaker trips, turn "Off" all power to the unit before attempting to reset it.

⚠ WARNING

Hazardous Voltage!

Disconnect all electric power, including remote disconnects before servicing. Follow proper lockout/tagout procedures to ensure the power can not be inadvertently energized. Failure to disconnect power before servicing could result in death or serious injury.

The transformer is located in the control panel. The circuit breaker is located on the left side of the transformer and can be reset by pressing in on the black reset button.

Controls Using 24 VAC

Before installing any connecting wiring, refer to "[Unit Dimensions](#)," [p. 12](#) for the electrical access locations provided on the unit and [Table 4, p. 22](#) for AC conductor sizing guidelines, and;

Installation

1. Use copper conductors unless otherwise specified.
2. Ensure that the AC control wiring between the controls and the unit's termination point does not exceed three (3) ohms/conductor for the length of the run.

NOTICE

Component Failure!

Resistance in excess of 3 ohms per conductor could result in component failure due to insufficient AC voltage supply.

3. Be sure to check all loads and conductors for grounds, shorts, and mis-wiring.
4. Do not run the AC low voltage wiring in the same conduit with the high voltage power wiring.
5. Route low voltage wiring per illustrations on [Figure 16, p. 22](#).

Table 4. Electromechanical thermostat 24 Vac conductors with ReliaTel™

| Distance from Unit to Control | Recommended Wire Size |
|-------------------------------|----------------------------------|
| 000 - 460 feet (000 - 140 m) | 18 gauge (0.75 mm ²) |
| 461 - 732 feet (141 - 223 m) | 16 gauge (1.3 mm ²) |
| 733 - 1000 feet (224 - 305 m) | 14 gauge (2.0 mm ²) |

Controls Using DC Analog Input/Outputs (Standard Low Voltage Multiconductor Wire)

Before installing any connecting wiring between the unit and components utilizing a DC analog input/output signal, refer to "Unit Dimensions," p. 12 for the electrical access locations provided on the unit.

1. [Table 5, p. 22](#) lists the conductor sizing guidelines that must be followed when interconnecting the DC binary output devices and the system components utilizing a DC analog input/output signal to the unit.

Note: Resistance in excess of 2.5 ohms per conductor can cause deviations in the accuracy of the controls.

2. Ensure that the wiring between controls and the unit's termination point does not exceed two and a half (2.5) ohms/conductor for the length of the run.
3. Do not run the electrical wires transporting DC signals in or around conduit housing high voltage wires.

Table 5. DC conductors zone sensor module wiring

| Distance from Unit to Control | Recommended Wire Size |
|----------------------------------|----------------------------------|
| 0 - 150 feet (0 - 45.7 m) | 22 gauge (0.33 mm ²) |
| 151 - 240 feet (46 - 73.1 m) | 20 gauge (0.50 mm ²) |
| 241 - 385 feet (73.5 - 117.3 m) | 18 gauge (0.75 mm ²) |
| 386 - 610 feet (117.7 - 185.9 m) | 16 gauge (1.3 mm ²) |
| 611 - 970 feet (186.2 - 295.7 m) | 14 gauge (2.0 mm ²) |

Figure 16. Reliatel conventional thermostat field wiring diagram

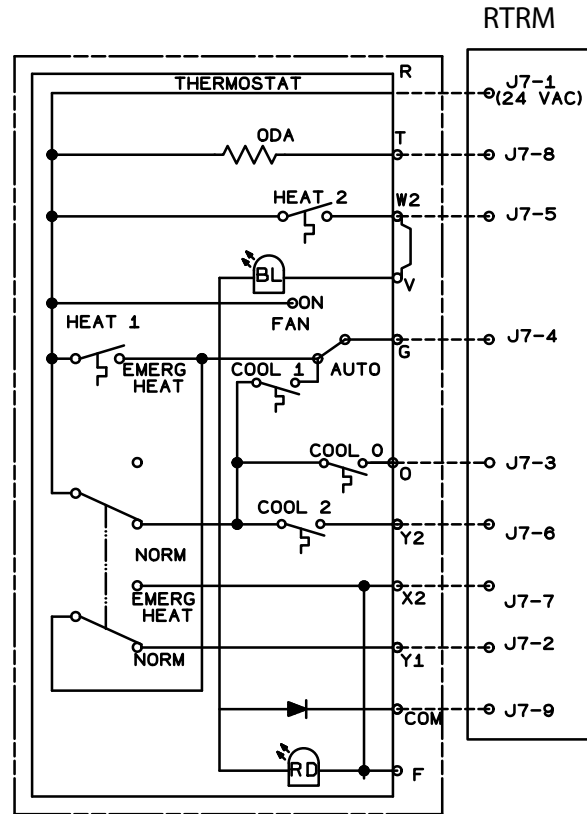
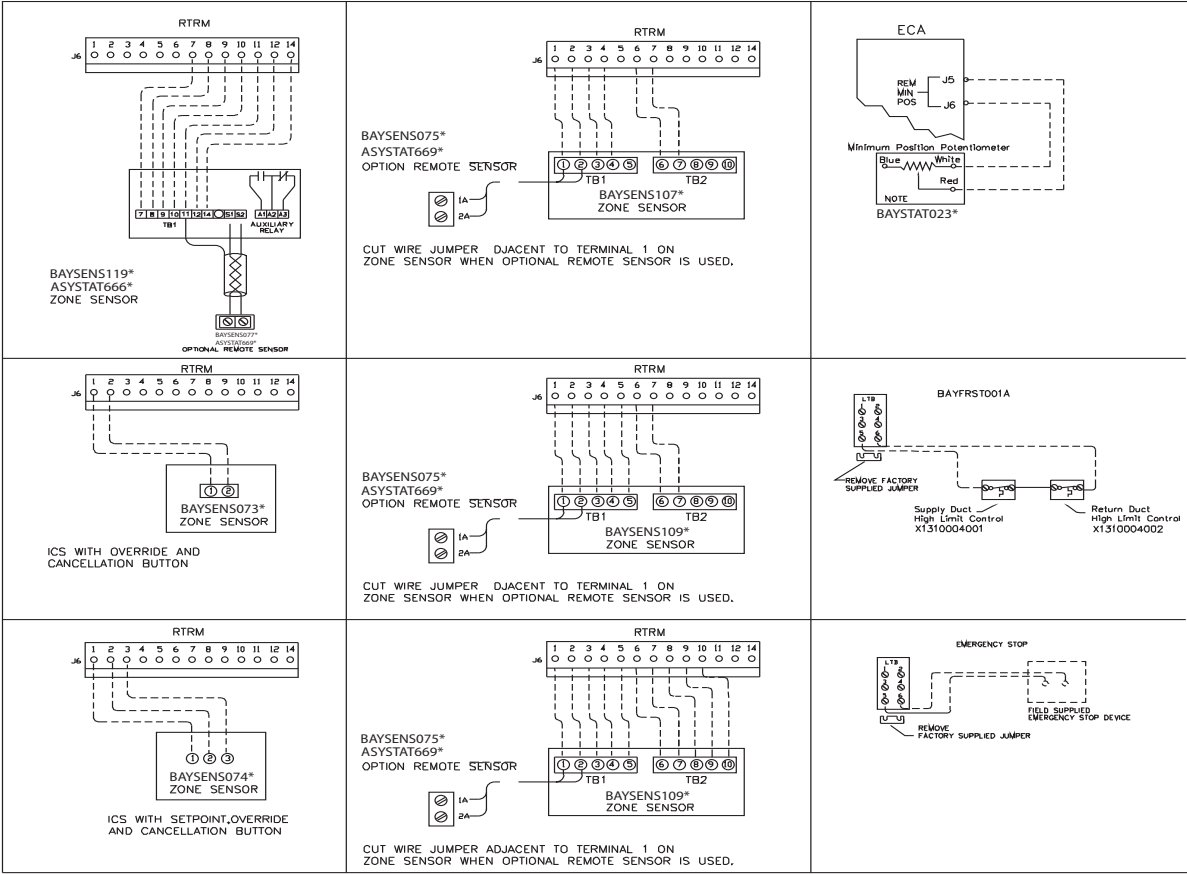
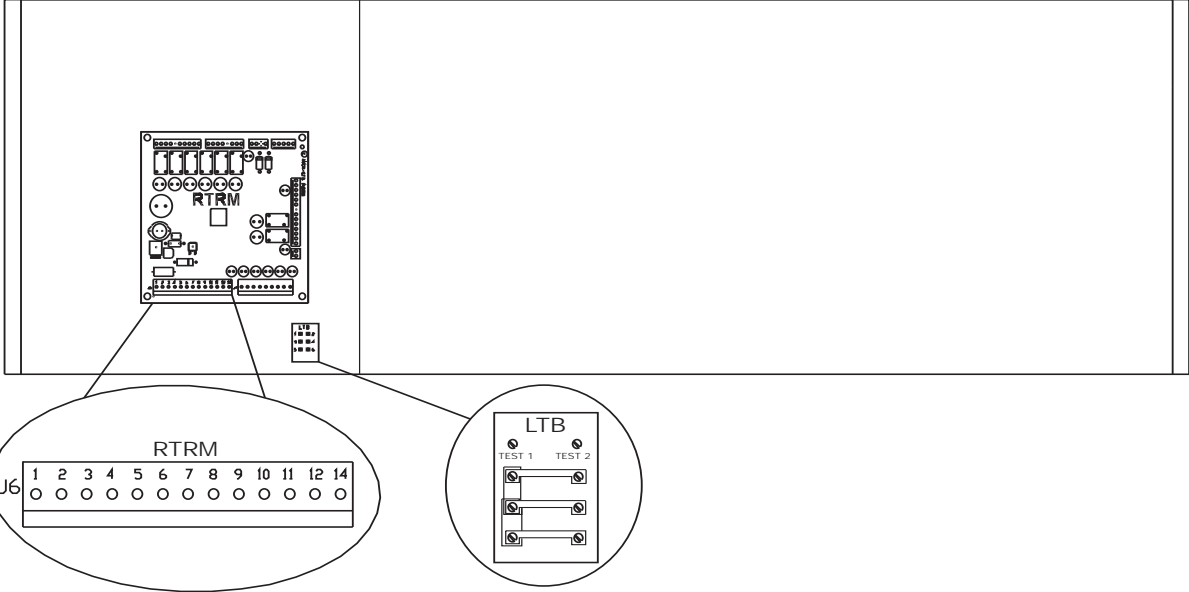

Figure 17. Typical field wiring diagrams for optional controls



CONTROL BOX



Installation

Space Temperature Averaging

Space temperature averaging is accomplished by wiring a number of remote sensors in a series/parallel circuit.

Using the BAYSENS016* or BAYSENS075*, at least four sensors are required to accomplish space temperature averaging. Example #1 illustrates two series circuits with two sensors in each circuit wired in parallel.

Figure 18. Space temperature averaging examples

any number of remote sensors is required. Example #2 illustrates three sensors squared in a series/parallel circuit. Using BAYSENS075*, two sensors are required to accomplish space temperature averaging. Example #3 illustrates the circuit required for this sensor. Table 6, p. 25 lists the temperature versus resistance coefficient for all sensing.

EXAMPLE #1

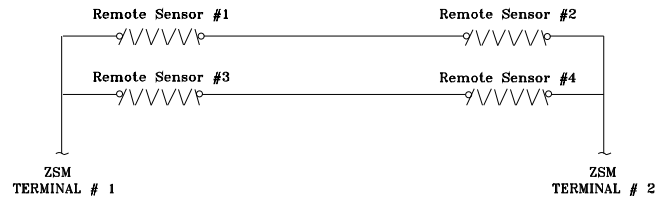
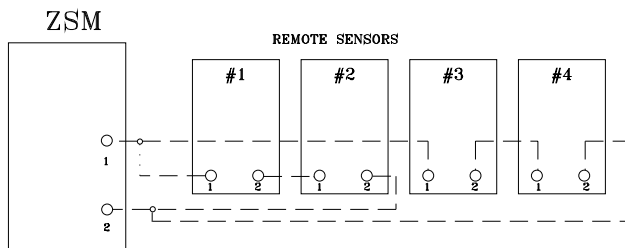

EXAMPLE #2

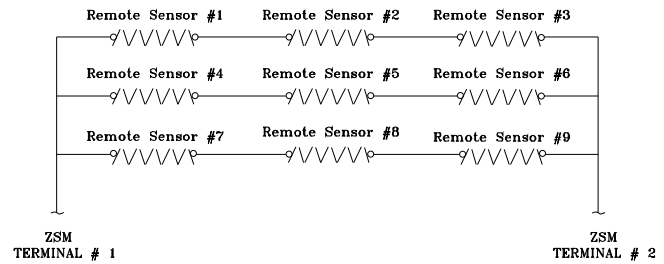
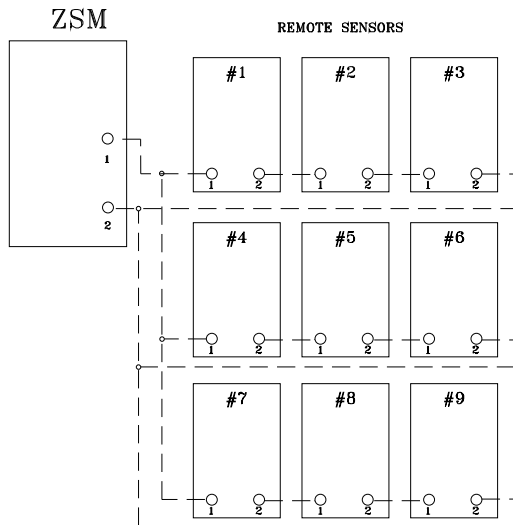

EXAMPLE #3

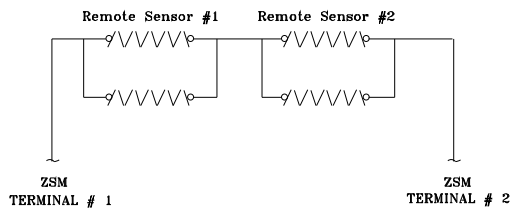
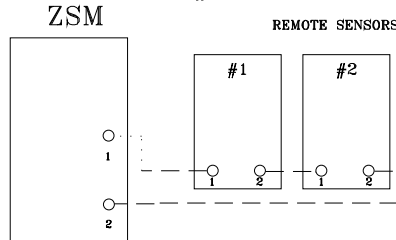

Table 6. Temperature vs. resistance

| Temperature | | Nominal Resistance |
|-------------|------------|--------------------|
| Degrees F° | Degrees C° | |
| -20° | -28.9° | 170.1 K - Ohms |
| -15° | -26.1° | 143.5 K - Ohms |
| -10° | -23.3° | 121.4 K - Ohms |
| -5° | -20.6° | 103.0 K - Ohms |
| 0° | -17.8° | 87.56 K - Ohms |
| 5° | -15.0° | 74.65 K - Ohms |
| 10° | -12.2° | 63.80 K - Ohms |
| 15° | -9.4° | 54.66 K - Ohms |
| 20° | -6.7° | 46.94 K - Ohms |
| 25° | -3.8° | 40.40 K - Ohms |
| 30° | -1.1° | 34.85 K - Ohms |
| 35° | 1.7° | 30.18 K - Ohms |
| 40° | 4.4° | 26.22 K - Ohms |
| 45° | 7.2° | 22.85 K - Ohms |
| 50° | 10.0° | 19.96 K - Ohms |
| 55° | 12.8° | 17.47 K - Ohms |
| 60° | 15.6° | 15.33 K - Ohms |
| 65° | 18.3° | 13.49 K - Ohms |
| 70° | 21.1° | 11.89 K - Ohms |
| 75° | 23.9° | 10.50 K - Ohms |
| 80° | 26.7° | 9.297 K - Ohms |
| 85° | 29.4° | 8.247 K - Ohms |
| 90° | 32.2° | 7.330 K - Ohms |
| 95° | 35.0° | 6.528 K - Ohms |
| 100° | 37.8° | 5.824 K - Ohms |

Voltage Imbalance

Three phase electrical power to the unit must meet stringent requirements for the unit to operate properly. Measure each leg (phase-to-phase) of the power supply. Each reading must fall within the utilization range stamped on the unit nameplate. If any of the readings do not fall within the proper tolerances, notify the power company to correct this situation before operating the unit.

Excessive three phase voltage imbalance between phases will cause motors to overheat and eventually fail. The maximum allowable voltage imbalance is 2%. Measure and record the voltage between phases 1, 2, and 3 and calculate the amount of imbalance as follows:

% Voltage Imbalance =

$$100\left(\frac{AV - VD}{AV}\right)$$

where Average Voltage (AV);

$$AV = \left(\frac{Volt1 + Volt2 + Volt3}{3}\right)$$

V1, V2, V3 = Line Voltage Readings

VD = Line Voltage reading that deviates the farthest from the average voltage.

Example: If the voltage readings of the supply power measured 221, 230, and 227, the average volts would be:

$$\frac{221 + 230 + 227}{3} = 2.2\text{percent}$$

VD (reading farthest from average) = 221

The percentage of Imbalance equals:

$$100\left(\frac{226 - 221}{226}\right) = 2.2\text{percent}$$

The 2.2% imbalance in this example exceeds the maximum allowable imbalance of 2.0%. This much imbalance between phases can equal as much as a 20% current imbalance with a resulting increase in motor winding temperatures that will decrease motor life. If the voltage imbalance is over 2%, notify the proper agencies to correct the voltage problem before operating this equipment.

Electrical Phasing (Three Phase Motors)

The compressor motor(s) and the supply fan motor are internally connected for the proper rotation when the incoming power supply is phased as A, B, C.

Proper electrical supply phasing can be quickly determined and corrected before starting the unit by using an instrument such as an Associated Research Model 45 Phase Sequence Indicator and following the steps below:

- Turn the field supplied disconnect switch that provides power to the main power terminal block or to the "Line" side of the optional factory mounted disconnect switch to the "Off" position.
- Connect the phase sequence indicator leads to the terminal block or to the "Line" side of the optional factory mounted disconnect switch as follows;
 - Black (phase A) to L1
 - Red (phase B) to L2
 - Yellow (phase C) to L3
- Close the field supplied main power disconnect switch or circuit protector switch that provides the supply power to the unit.
- Observe the ABC and CBA phase indicator lights on the face of the sequencer. The ABC indicator light will glow if the phase is ABC. If the CBA indicator light glows, open the disconnect switch or circuit protection switch and reverse any two power wires.
- Restore the main electrical power and recheck the phasing. If the phasing is correct, open the disconnect switch or circuit protection switch and remove the phase sequence indicator.

Installation

Compressor Crankcase Heaters

NOTICE

Compressors Failure!

Unit must be powered and crankcase heaters energized at least 8 hours BEFORE compressors are started. This will protect the compressors from premature failure.

Each compressor is equipped with a crankcase heater. The proper operation of the crankcase heater is important to maintain an elevated compressor oil temperature during the "Off" cycle to reduce oil foaming during compressor starts. Oil foaming occurs when refrigerant condenses in the compressor and mixes with the oil. In lower ambient conditions, refrigerant migration to the compressor could increase.

When the compressor starts, the sudden reduction in crankcase pressure causes the liquid refrigerant to boil rapidly causing the oil to foam. This condition could damage compressor bearings due to reduced lubrication and could cause compressor mechanical failures.

Before starting the unit in the "Cooling" mode, set the system switch to the "Off" position and turn the main power disconnect to the "On" position and allow the crankcase heater to operate a minimum of 8 hours.

Before closing the main power disconnect switch, insure that the "System" selection switch is in the "Off" position and the "Fan" selection switch is in the "Auto" position.

Close the main power disconnect switch and the unit mounted disconnect switch, if applicable.

ReliaTel Controls

Upon power initialization, the RTRM performs self-diagnostic checks to insure that all internal controls are functional. It also checks the configuration parameters against the components connected to the system. The Liteport LED located on the RTRM module is turned "On" within one second of power-up if internal operation is okay.

Use one of the following "Test" procedure to bypass some time delays and to start the unit at the control panel. Each step of unit operation can be activated individually by temporarily shorting across the "Test" terminals for two to three seconds. The Liteport LED located on the RTRM module will blink when the test mode has been initiated. The unit can be left in any "Test" step for up to one hour before it will automatically terminate, or it can be terminated by opening the main power disconnect switch. Once the test mode has been terminated, the Liteport LED will glow continuously and the unit will revert to the "System" control.

Final Steps

Use the checklist provided below in conjunction with the checklist in "[General Unit Requirements](#)," p. 19, to ensure that the unit is properly installed and ready for operation.

- Check all electrical connections for tightness and "point of termination" accuracy.
- Verify that the condenser airflow is unobstructed.
- Verify that the condenser fan and indoor blower turn freely without rubbing and are properly tightened on the shafts.
- Check the supply fan belts for proper tension and the fan bearings for sufficient lubrication. If the belts require adjustment, or if the bearings need lubricating, refer to the maintenance section of this manual for instructions.
- Verify that a condensate trap is installed and the piping is properly sized and pitched.
- Verify that the correct size and number of filters are in place.
- Inspect the interior of the unit for tools and debris and install all panels in preparation for starting the unit.

Factory-Mounted Unit Options

Circuit Breaker (FIYUCB) and Unit Disconnect (FIYUDC)

⚠ WARNING

Hazardous Voltage w/Capacitors!

Disconnect all electric power, including remote disconnects and discharge all motor start/run capacitors before servicing. Follow proper lockout/tagout procedures to ensure the power cannot be inadvertently energized. Verify with an appropriate voltmeter that all capacitors have discharged. Failure to disconnect power and discharge capacitors before servicing could result in death or serious injury.

For additional information regarding the safe discharge of capacitors, see PROD-SVB06*-EN

⚠ WARNING

Proper Field Wiring and Grounding Required!

All field wiring **MUST** be performed by qualified personnel. Improperly installed and grounded field wiring poses **FIRE** and **ELECTROCUTION** hazards. To avoid these hazards, you **MUST** follow requirements for field wiring installation and grounding as described in NEC and your local/state electrical codes. Failure to follow code could result in death or serious injury.

Important: All phases of this installation must comply with NATIONAL, STATE, and LOCAL CODES. In addition to local codes, the installation must comply with National Electric Code - ANSI/NFPA NO. 70 LATEST REVISION.

1. Field connections are made by first removing all access panels on the front of the unit. Unscrew the assembly around the outside of the disconnect switch or circuit breaker. This assembly is located between the evaporator and heat section of the unit (Figure 19, p. 27).

For downflow configurations, the hole in the base section is for both high and low voltage power wiring on down flow units. Horizontal units will route through the front plate located directly under the circuit breaker or disconnect panel. The hole is sized for 1 1/2" conduit. Horizontal units will use the front plate located directly under the circuit breaker panel.

2. If the conduit required for your application is larger, remove the termination plate and connect to the larger hole using field supplied reducing washers.
3. Route the power wires and ground conductor through conduit and into the bottom of the factory installed disconnect switch or circuit breaker. Connect the

power conductors to the lugs provided. Connect the ground wire to the unit ground lug.

Note: Wire size for the length of run should be determined using the circuit ampacity found on the unit nameplate and the N.E.C.

4. Route low voltage (class II), control wiring through hole in base of unit but not through high voltage conduit. Feed control wiring through bushing provided on side panel and into the flexible conduit provided in the heat section of the unit (Figure 19). Route wires through loose wire ties provided in unit as in Figure 19.
5. Tighten the wire ties. Secure the excess wire bundle under the wire ties in the outdoor section. Do not leave excess wire in the electrical enclosure. Use the unit wiring diagram to make the low voltage connections.

Figure 19. Main power entrance for units with factory mounted disconnect or circuit breaker

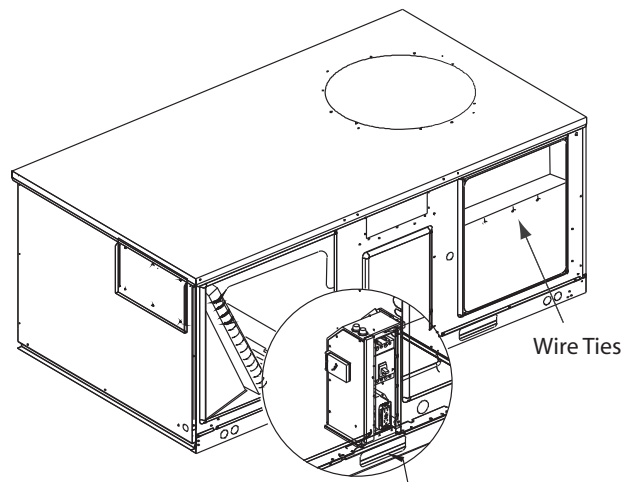

Main power entrance for units with factory mounted disconnect or circuit breaker

Powered/Unpowered Convenience Outlet

⚠ WARNING

Hazardous Voltage w/Capacitors!

Disconnect all electric power, including remote disconnects and discharge all motor start/run capacitors before servicing. Follow proper lockout/tagout procedures to ensure the power cannot be inadvertently energized. Verify with an appropriate voltmeter that all capacitors have discharged. Failure to disconnect power and discharge capacitors before servicing could result in death or serious injury.

For additional information regarding the safe discharge of capacitors, see PROD-SVB06-EN*

⚠ WARNING

Proper Field Wiring and Grounding Required!

All field wiring **MUST** be performed by qualified personnel. Improperly installed and grounded field wiring poses **FIRE** and **ELECTROCUTION** hazards. To avoid these hazards, you **MUST** follow requirements for field wiring installation and grounding as described in **NEC** and your local/state electrical codes. Failure to follow code could result in death or serious injury.

Powered Convenience Outlet Powered Option (FIYCOPO)

When the powered convenience outlet option is installed, the unit will include a dedicated transformer located in the evaporator section of the unit. Additionally, a service receptacle disconnect switch will be provided on the side wall of the evaporator section. The service receptacle switch is shipped in the OFF position.

The powered outlet comes completely wired from the factory except for 208 volt applications.

- For 208 volt applications, disconnect and tape the blue 230 volt wire.
- Then connect the brown 208 volt wire.

Figure 20. Wiring schematic 12½ through 25 ton options

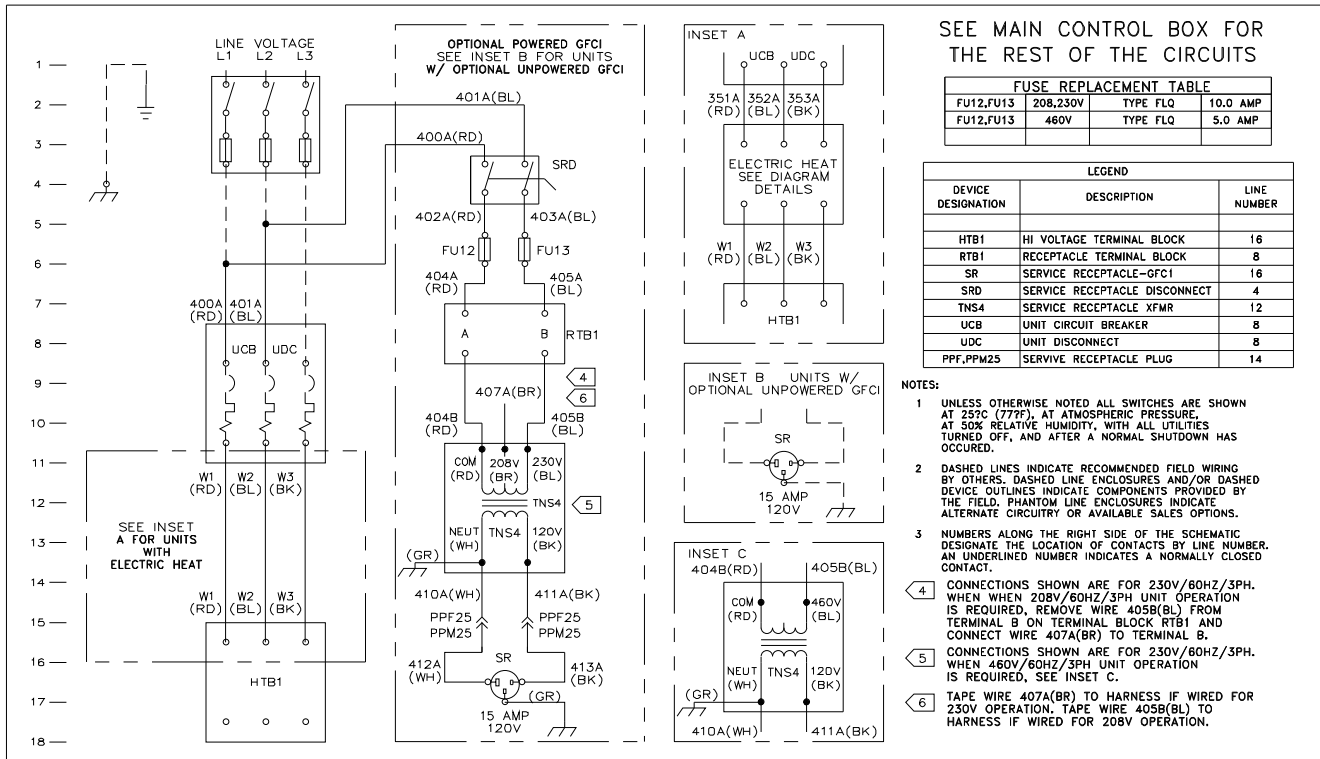

Unpowered Convenience Outlet Unpowered Option (FIYCOUP)

- When the unpowered convenience outlet option is installed, remove the receptacle.

- The field wiring should be routed through the hole in the base for downflow applications or front panel for horizontal applications then through holes provided in the "J" box (bottom for EMT and top for flexible conduit).
- Connect the three (3) wires to terminals inside outlet box.

Figure 21. Power options

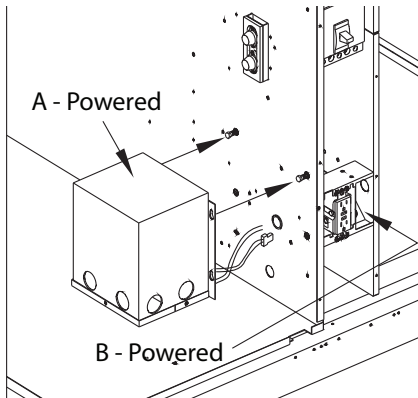

Return Air Smoke Detector

Pre-Requisite

Note: The following field installation instructions apply to downflow only. Horizontal return air smoke detectors require no field installation.

When a unit is ordered with a downflow economizer and a return air smoke detector as factory installed options, the return air smoke detector cannot be completely installed because the economizer, when it is in the shipping position, is occupying the space where the return air smoke detector is to be installed.

The partial assembly and set-up required for each factory installed economizer must be completed up to the point where the barometric relief hood is to be installed into the unit. Prior to this operation, go to Step 5 of this instruction and perform the operations described there. After this is completed, the economizer installation is to be completed in its entirety as outlined in the installation guide.

Smoke Detector Installation

Important: The shipping screw that holds the barometric relief damper must be removed before proceeding with the smoke detector installation.

After completion of the economizer installation as outlined above, proceed with the installation of the return air smoke detector as follows:

⚠ WARNING

Hazardous Voltage w/Capacitors!

Disconnect all electric power, including remote disconnects and discharge all motor start/run capacitors before servicing. Follow proper lockout/tagout procedures to ensure the power cannot be inadvertently energized. Verify with an appropriate voltmeter that all capacitors have discharged. Failure to disconnect power and discharge capacitors before servicing could result in death or serious injury.

For additional information regarding the safe discharge of capacitors, see PROD-SVB06-EN*

⚠ WARNING

Proper Field Wiring and Grounding Required!

All field wiring **MUST** be performed by qualified personnel. Improperly installed and grounded field wiring poses **FIRE** and **ELECTROCUTION** hazards. To avoid these hazards, you **MUST** follow requirements for field wiring installation and grounding as described in **NEC** and your local/state electrical codes. Failure to follow code could result in death or serious injury.

- Remove the smoke detector assembly from its shipping position in the indoor fan compartment. This assembly is attached with three screws to the indoor fan board near the top of the unit.
- Remove and discard the shipping bracket from the smoke detector assembly. This is the angled piece of sheet metal that secured the smoke detector assembly to the interior parts of the unit during shipment.
- Place the end of the smoke detector 16 inch metal exhaust tube provided into the bottom hole in the back of the smoke detector. Line up the tab in the exhaust tube with one of the slots in the detector and insert the tube until the tube can be rotated. Rotate the tube 45 degrees to lock it in place.

Figure 22. Brackets

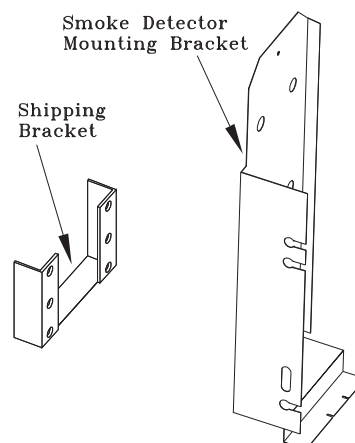

Factory-Mounted Unit Options

Figure 23. Return air smoke detector for downflow units

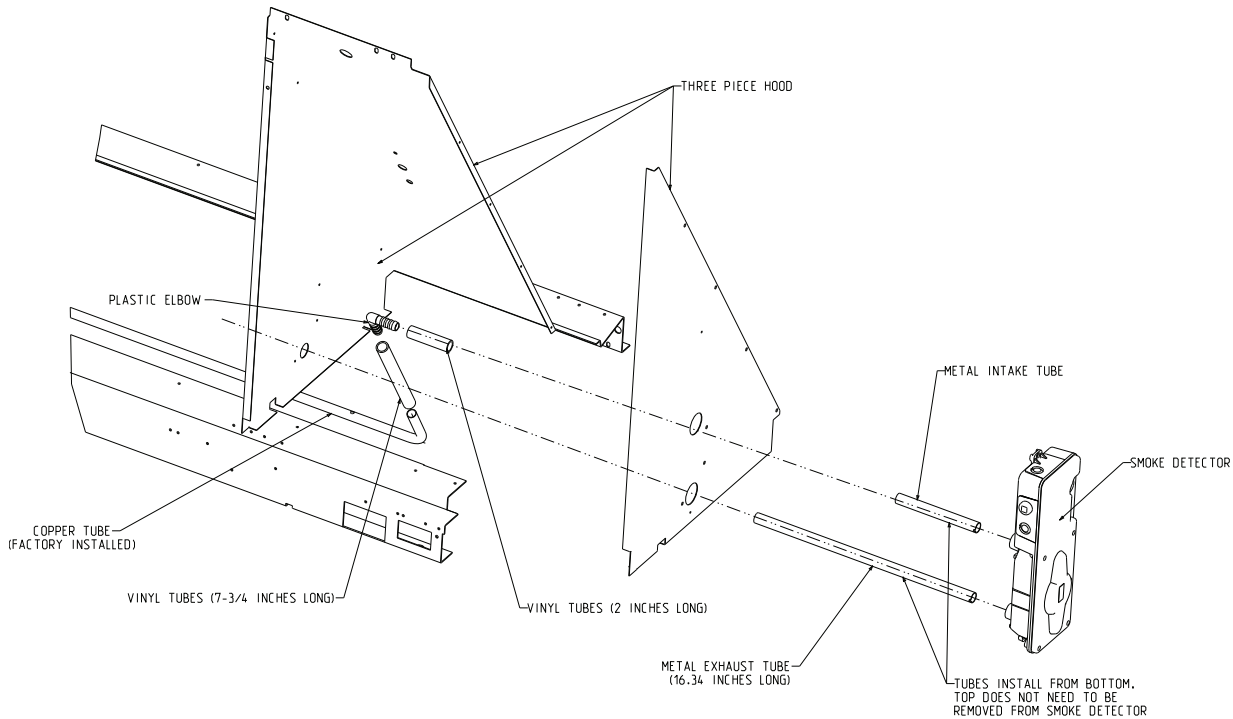

4. Slide one 2" piece of the vinyl tubing provided onto the short smoke detector inlet tube which protrudes out of the back side of the smoke detector. Push this piece of vinyl tubing onto the inlet tube until it contacts the end of the plastic extension on the backside of the smoke detector.
 5. Slide the long piece of vinyl tubing provided onto one leg of the plastic barbed elbow provided. Slide the other end of this piece of vinyl tubing with the elbow attached approximately 1" onto the end of the copper sampling tube installed in the unit's return air opening. Position the leg of elbow without the vinyl tubing such that it points toward the front side of the unit (directly out of the unit toward the filter access panel).
 6. Mount the smoke detector assembly into the unit. Align the smoke detector (exhaust tube down) with the holes in the outer panel of the barometric relief hood and position the smoke detector flush on the panel.
- inside through the barometric relief outlet to access and connect the copper exhaust elbow to the smoke detector exhaust tube.*
8. Connect the leg of the plastic elbow without the vinyl tubing attached that was installed in [Step 5](#) to the smoke detector inlet tube pushing it onto the piece of vinyl tubing attached to the inlet tube.
 9. Refer to [Figure 24, p. 31](#) for wire connections of return air smoke detector to the unit wiring harness.
 10. This completes the installation of the return air smoke detector. If the unit's air filter(s) and/or barometric relief filter were removed to ease installation of the smoke detector, they need to be replaced at this time.

Note: On all units there is a hole with a plastic snap bushing located on the inner vertical side of the barometric relief hood that the long exhaust tube must pass through. Be sure that the exhaust tube is aligned with this hole before positioning the smoke detector flush on the outer panel of the barometric relief hood.

7. Secure the smoke detector to the hood with two #10-16 x 3/4" sheet metal screws provided.

Note: In order to perform the last part of this operation, it will be necessary to remove the barometric relief filter, open the barometric relief damper, and reach

Airflow and Sampling

Refer to the instructions provided below regarding unit airflow to assure that the return air smoke detector will function properly.

Important: The return air smoke detector is designed to shut off the unit if smoke is sensed in the return air stream. This function is performed by sampling the airflow entering the unit at the return air opening. Follow the instructions provided below to assure that the airflow through the unit is sufficient for adequate sampling. Failure to follow these instructions will prevent the smoke detector from performing its design function.

In order for the return air smoke detector to properly sense smoke in the return air stream, the air velocity entering the unit must be between 500 and 4000 feet per minute.

Notes:

- Airflow through the unit is affected by the amount of dirt and debris accumulated on the indoor coil and filters. To insure that airflow through the unit is adequate for proper sampling by the return air smoke detector, complete adherence to the maintenance procedures, including recommended intervals between filter changes and coil cleaning, is required.
- Periodic checks and maintenance procedures must be performed on the smoke detector to insure that it will function properly. For detailed instructions concerning these checks and procedures, refer to the appropriate section(s) of the smoke detector Installation and Maintenance Instructions provided with the literature package for this unit.

Important: Refer to the service literature provided for testing and other information about the smoke detector or if problems are encountered.

Figure 24. Smoke detector wiring scheme

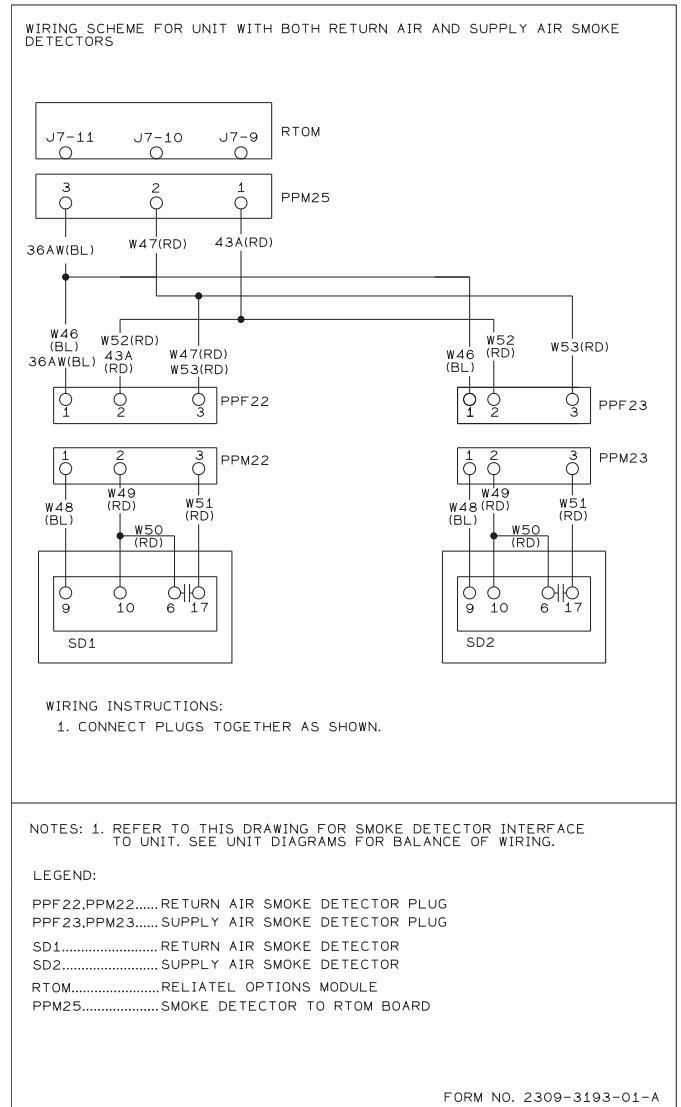

Factory-Mounted Unit Options

Air-Fi™ Wireless Communication Interface (WCI)

When installed, the Trane Air-Fi Wireless Communication Interface is located in the evaporator section, near the return air ductwork. The exact mounting location is dependent on the airflow configuration, cabinet size, and fresh air selection. Refer to Figure 25 through Figure 27.

Refer to BAS-SVX40*-EN for instructions and troubleshooting procedures.

Figure 25. WCI mounting location - SD150-240

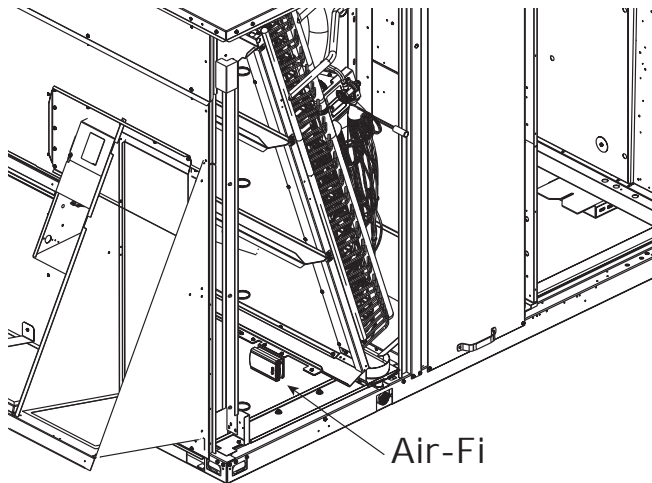

Figure 26. WCI mounting location - H150-240

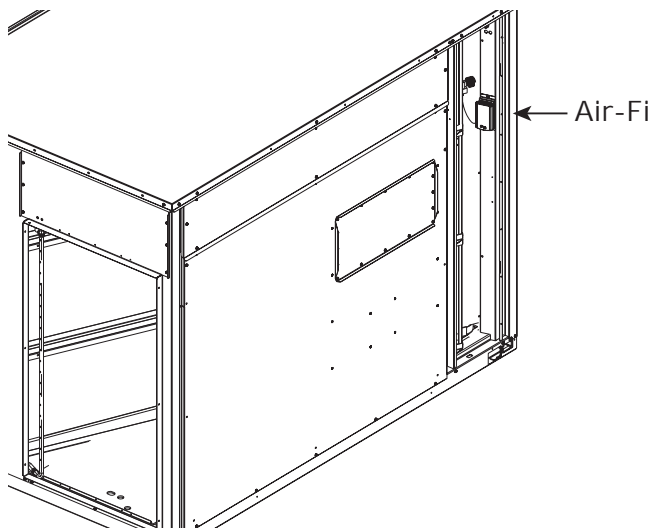
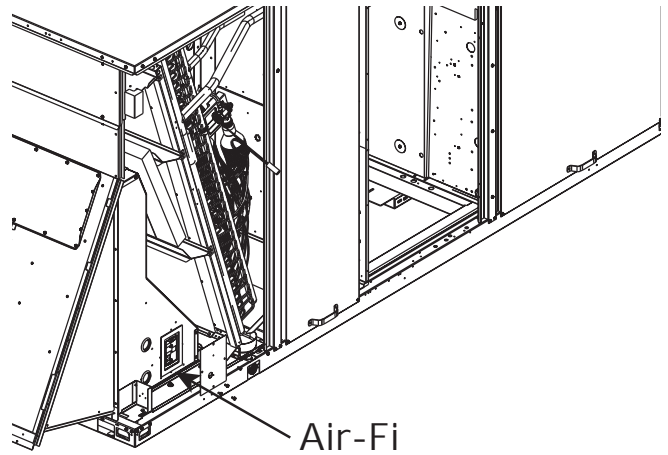

Figure 27. WCI mounting location - D150-240 - with low leak economizer



Pre-Start

Test Modes

There are three methods in which the “Test” mode can be cycled at LTB-Test 1 and LTB-Test 2.

1. Step Test Mode - This method initiates the different components of the unit, one at a time, by temporarily shorting across the two test terminals for two to three seconds.

For the initial start-up of the unit, this method allows the technician to cycle a component “On” and have up to one hour to complete the check.

2. Resistance Test Mode - This method can be used for start-up providing a decade box for variable resistance outputs is available. This method initiates the different components of the unit, one at a time, when a specific

resistance value is placed across the two test terminals. The unit will remain in the specific test mode for approximately one hour even though the resistance is left on the test terminals.

3. Auto Test Mode - This method is not recommended for start-up due to the short timing between individual component steps. This method initiates the different components of the unit, one at a time, when a jumper is installed across the test terminals. The unit will start the first test step and change to the next step every 30 seconds. At the end of the test mode, control of the unit will automatically revert to the applied “System” control method.

For unit test steps, test modes, and step resistance values to cycle the various components, refer to [Table 7, p. 33](#).

Table 7. Service test guide for component operation

| TEST STEP | MODE | Fan | Econ ^(a) | Comp 1 | Comp 2 | Heat 1 | Heat 2 | Ohms |
|------------------|----------------------|-----|----------------------------------|-------------------|-------------------|--------|--------|------|
| 1 | Fan | On | Minimum Position Off Setpoint 0% | Off | Off | Off | 2.2K | |
| | Minimum Ventilation | On | Selectable | Off | Off | Off | Off | |
| 2 | Economizer Test Open | On | Open | Off | Off | Off | Off | 3.3K |
| 3 | Cool Stage 1 | On | Minimum Position | On ^(b) | Off | Off | Off | 4.7K |
| 4 ^(c) | Cool Stage 2 | On | Minimum Position | On ^(b) | On ^(b) | Off | Off | 6.8K |
| 5 ^(c) | Reheat | On | Minimum | On | On | Off | Off | 33K |
| 6 ^(c) | Heat Stage 1 | On | Minimum | Off | Off | On | Off | 10K |
| 7 ^(c) | Heat Stage 2 | On | Minimum | Off | Off | On | On | 15K |

(a) The exhaust fan will turn on anytime the economizer damper position is equal to or greater than the exhaust fan setpoint.

(b) The condenser fans will operate any time a compressor is “On” providing the outdoor air temperatures are within the operating values.

(c) Steps for optional accessories and non-applicable modes in unit will be skipped.

Pre-Start

Verifying Proper Air Flow (Units with Belt Drive Indoor Fan)

Much of the systems performance and reliability is closely associated with, and dependent upon having the proper airflow supplied both to the space that is being conditioned and across the evaporator coil.

The indoor fan speed is changed by opening or closing the adjustable motor sheave.

Before starting the SERVICE TEST, set the minimum position setpoint for the economizer to 0 percent using the setpoint potentiometer located on the Economizer Control (ECA), if applicable.

ReliaTel Control

Using the Service Test Guide in [Table 7, p. 33](#), momentarily jump across the Test 1 & Test 2 terminals on LTB1 one time to start the Minimum Ventilation Test.

Once the supply fan has started, check for proper rotation. The direction of rotation is indicated by an arrow on the fan housing.

With the fan operating properly, determine the total system airflow (CFM) by;

1. Measuring the actual RPM,
2. Measure the amperage at the supply fan contactor and compare it with the full load amp (FLA) rating stamped on the motor nameplate.
 - a. Calculate the theoretical BHP

Actual Motor Amps X Motor HP

Motor Nameplate Amps

- b. Using the fan performance tables in the unit Service Facts, plot the actual RPM (step 1) and the BHP (step 2a) to obtain the operating CFM.
3. If the required CFM is too low, (external static pressure is high causing motor HP output to be below table value),
 - a. Relieve supply and/or return duct static.
 - b. Change indoor fan speed and repeat steps 1 and 2.
 - To Increase Fan RPM; Loosen the pulley adjustment set screw and turn sheave clockwise.
 - To Decrease Fan RPM; Loosen the pulley adjustment set screw and turn sheave counterclockwise.
 - If the required CFM is too high, (external static pressure is low causing motor HP output to be above table value), change indoor fan speed and repeat steps 1 and 2.
 - To stop the SERVICE TEST, turn the main power disconnect switch to the "Off" position or proceed to the next component start-up procedure. Remove electro mechanical test mode connections (if applicable).

Return Air Smoke Detector

The return air smoke detector is designed to shut off the unit if smoke is sensed in the return air stream. Sampling the airflow entering the unit at the return air opening performs this function.

In order for the smoke detector to properly sense smoke in the return air stream, the air velocity entering the unit must be between 500 and 4000 feet per minute. Equipment covered in this manual will develop an airflow velocity that falls within these limits over the entire airflow range specified in the evaporator fan performance tables.

Start Up

Economizer Start-Up

Using the Service Test Guide in [Table 7, p. 33](#), momentarily jump across the Test 1 & Test 2 terminals on LTB1 one time to start the Minimum Ventilation Test.

1. Set the minimum position setpoint for the economizer to the required percentage of minimum ventilation using the setpoint potentiometer located on the Economizer Control Actuator (ECA).

The economizer will drive to its minimum position setpoint, exhaust fans (if applicable) may start at random, and the supply fan will start when the SERVICE TEST is initiated.

The Exhaust Fan will start anytime the economizer damper position is equal to or greater than the exhaust fan setpoint.

2. Verify that the dampers stroked to the minimum position.
3. Momentarily jump across the Test 1 & Test 2 terminals on LTB one additional time if continuing from previous component start-up or until the desired start-up component Test is started.
4. Verify that the dampers stroked to the full open position.
5. To stop the SERVICE TEST, turn the main power disconnect switch to the "Off" position or proceed to the next component start-up procedure. Remove electro mechanical test mode connections (if applicable).

Compressor Start-Up

1. Attach a set of service gauges onto the suction and discharge gauge ports for each circuit. Refer to the refrigerant circuit illustration in the Service Facts.

Using the Service Test Guide in [Table 7, p. 33](#), continue the SERVICE TEST start-up procedure for each compressor circuit.

Momentarily jump across the Test 1 & Test 2 terminals on LTB1 one additional time if continuing from previous component start-up or until the desired start-up component Test is started.

Scroll Compressors

- a. Once each compressor has started, verify that the rotation is correct. To check rotation, use a set of refrigeration gauges hooked up to the suction and discharge pressure port. If the compressor is phased correctly the suction pressure should drop and the discharge pressure should rise when the compressor starts and runs. If a scroll compressor is rotating backwards, it will not pump, the suction and discharge pressure will not rise, and a loud rattling sound can be observed.

- b. If the electrical phasing is incorrect, before condemning a compressor, interchange any two leads (at the compressor Terminal block) to check the internal phasing. Refer to the following illustration for the compressor terminal/phase identification. If the compressor runs backward for an extended period not to exceed 5 seconds, the compressor will be damaged the motor winding can overheat and cause the motor winding thermostat to open and the oil can turn dark gray.
- c. Check the compressor oil levels. The oil level in each compressor sight glass should be visible in the compressor sightglass. This only applies to CSHD compressors, SSA and SPA compressors don't have sight glasses.

Note: The Copeland, SSA and SPA scroll compressors for R-410A units use Trane OIL00094. The correct Oil for Trane CSHD is Trane OIL00079 or OIL00080. Compressor types are listed in the table below. The appropriate oil charge is also listed below

2. After the compressor and condenser fan have started and operated for approximately 30 minutes, observe the operating pressures. Compare the operating pressures to the operating pressure curve in the Service Facts.
3. Check system superheat. Follow the instruction listed on the superheat charging curve in the Service Facts. Superheat should be within $\pm 5^{\circ}\text{F}$ of the superheat chart value.
4. Repeat steps 1 through 4 for each refrigerant circuit.
5. To stop the SERVICE TEST, turn the main power disconnect switch to the "Off" position or proceed to the next component start-up procedure.
6. The Copeland, SSA and SPA scroll compressors for R-410A units use Trane OIL00094. The correct Oil for Trane CSHD is Trane OIL00079 or OIL00080. Compressor types are listed in the following table. The appropriate oil charge is also listed below.

Figure 28. Compressor terminal box

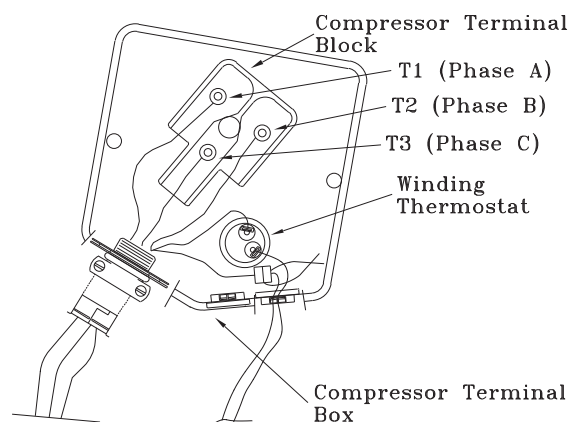

Start Up

Table 8. Oil charge

| Model | Circuit 1 | Circuit 2 |
|---------------|-----------|-----------|
| WS*150 | 56 oz | 56 oz |
| WS*155/WS*180 | 56 oz | 56 oz |
| WS*200/WS*240 | 112 oz | 112 oz |

Table 9. Compressor types

| Tonnage | C1 | C2 |
|---------------|---------|---------|
| WS*150 | SSA067 | SSA067 |
| WS*155/WS*180 | SSA083 | SSA083 |
| WS*200/WS*240 | CSHD125 | CSHD125 |

- Verify that all exterior panels including the control panel doors and condenser grilles are secured in place.
- Close the main disconnect switch or circuit protector switch that provides the supply power to the unit's terminal block or the unit mounted disconnect switch.

Heating Start-Up

1. Clamp an amp meter around one of 1st stage heater power wires at the heater contactor.
2. Using the Service Test Guide in [Table 7, p. 33](#), continue the SERVICE TEST start-up procedure for each compressor circuit.

Momentarily jump across the Test 1 & Test 2 terminals on LTB one additional time if continuing from previous component start-up or until the desired start-up component Test is started.

3. Verify that the heater stage is operating properly.
4. Clamp an amp meter around one of 2nd stage heater power wires at the heater contactor (if applicable).
5. Using the Service Test Guide in [Table 7, p. 33](#), continue the SERVICE TEST start-up procedure for each compressor circuit. Momentarily jump across the Test 1 & Test 2 terminals on LTB one additional time if continuing from previous component start-up or until the desired start-up component Test is started.
6. Verify that the heater stage is operating properly.
7. To stop the SERVICE TEST, turn the main power disconnect switch to the "Off" position or proceed to the next component start-up procedure.

Final System Setup

After completing all of the pre-start and start-up procedures outlined in the previous sections (i.e., operating the unit in each of its Modes through all available stages of cooling & heating), perform these final checks before leaving the unit:

- Program the Night Setback (NSB) panel (if applicable) for proper unoccupied operation. Refer to the programming instructions for the specific panel.
- Verify that the Remote panel "System" selection switch, "Fan" selection switch, and "Zone Temperature" settings for automatic operation are correct.
- Inspect the unit for misplaced tools, hardware, and debris.

Sequence of Operation

The ReliaTel Controls is a microelectronic control feature, which provides operating function that is significantly different than conventional electro-mechanical units. The master module is the ReliaTel Refrigeration Module (RTRM).

ReliaTel Controls

- The master module is the ReliaTel Refrigeration Module (RTRM).
- The RTRM provides compressor anti-short cycle timing functions through minimum "Off" and "On" timing to increase reliability, performance and to maximize unit efficiency.
- Upon power initialization, the RTRM performs self-diagnostic checks to insure that all internal controls are functioning. It checks the configuration parameters against the components connected to the system.
- The LED located on the RTRM module is turned "On" within one second after power-up if all internal operations are okay.
- The RTRM will provide capability to control of a multi-speed indoor motor (IDM).
- The ReliaTel Options Module (RTOM) is utilized in conjunction with the RTRM for control of a variable speed indoor motor (IDM) and optional accessories.
- All units employ a Phase Monitor to ensure proper power supply connection of phases for compressor operation. If the monitor senses incorrect phase connection (phase reversal), a loss of phase, or large voltage imbalance between phases, all unit operation will be prevented until the condition is corrected. The Phase Monitor has green (Ok) and red (Phase Fault) status LEDs on the face of the monitor. All units are functional tested to ensure correct factory wiring. A red status LED is an indication of a serious problem that can only be resolved by isolating and repairing the Supply Power fault.

ReliaTel Control Cooling without an Economizer

When the system switch is set to the "Cool" position and the zone temperature rises above the cooling setpoint controlband, the RTRM energizes the first stage compressor control provided the compressor protection conditions have been met. When the first stage compressor control and the outdoor fan motor are energized, they maintain the zone temperature to within $\pm 2^{\circ}\text{F}$ of the sensor setpoint at the sensed location. If the first stage of cooling cannot satisfy the cooling requirement, the RTRM energizes the second stage compressor control provided the compressor protection conditions have been met. When the second stage compressor is energized it starts to maintain the zone

temperature to within $\pm 2^{\circ}\text{F}$ of the sensor setpoint at the sensed location.

If the second stage of cooling cannot satisfy the cooling requirement, the RTRM energizes the third stage compressor control provided the compressor protection conditions have been met. When the third stage compressor control is energized it starts to maintain the zone temperature to within $\pm 2^{\circ}\text{F}$. If the third stage of cooling cannot satisfy the cooling requirement, the RTRM energizes the fourth stage compressor control provided the compressor protection conditions have been met. When the fourth stage compressor control is energized it starts to maintain the zone temperature to within $\pm 2^{\circ}\text{F}$.

ReliaTel Control Evaporator Fan Operation

With the indoor fan in "Auto" mode, the RTRM energizes the indoor fan motor for approximately 1 second after energizing the first stage compressor in the cooling mode. In the heating mode, the RTRM energizes the indoor fan motor approximately 45 seconds after gas ignition (gas heat unit) or 1 second before energizing electric heat (electric heat unit). With the indoor fan in "On" mode, the RTRM keeps the indoor fan energized for continuous fan motor operation. When the unit is equipped with the optional clogged filter switch, wired to the ReliaTel Options Module (RTOM), the RTRM produces an analog signal output if the clogged filter switch (CFS) closes for two minutes after a request for fan operation. When the system is connected to a remote panel, the "SERVICE" LED will be turned on when this failure occurs.

Drain Pan Condensate Overflow Switch (Optional)

This input incorporates the Condensate Overflow Switch (COF) mounted on the drain pan and the ReliaTel Options Module (RTOM). When the condensate level reaches the trip point for 6 continuous seconds, the RTOM will shut down all unit function until the overflow condition has cleared. The unit will return to normal operation after 6 continuous seconds with the COF in a non-tripped condition. If the condensate level causes the unit to shutdown more than 2 times in a 3 day period, the unit will be locked-out of operation. A manual reset of the diagnostic system through the Zone Sensor or Building Automation System (BAS) will be required. Cycling unit power will also clear the fault.

Low Ambient Operation

During low ambient operation, outside air temperature below 40°F , the RTRM will cycle the compressor and outdoor fan motor "Off" for approximately 3 minutes after every 10 minutes of accumulated compressor run time. The indoor fan motor (IDM) will continue to operate during this evaporator defrost cycle (EDC) and the compressor and outdoor fan will return to normal operation once the

Sequence of Operation

defrost cycle has terminated and the compressor "Off" time delay has been satisfied.

ReliaTel Control Cooling with an Economizer

The economizer is utilized to control the zone temperature providing the outside air conditions are suitable. Outside air is drawn into the unit through modulating dampers. When cooling is required and economizing is possible, the RTRM sends the cooling request to the unit economizer actuator (ECA) to open the economizer damper. The RTRM tries to cool the zone utilizing the economizer to slightly below the zone temperature setpoint. If the mixed air sensor (MAS) senses that the mixed air temperature is below 53°F, the damper modulates toward the closed position. If the zone temperature continues to rise above the zone temperature setpoint controlband and the economizer damper is fully open, the RTRM energizes the first stage of compressor control and latches the economizer fully open as long as any compressor is energized. If the zone temperature continues to rise above the zone temperature setpoint controlband, the RTRM energizes the second stage of compressor control. If the zone temperature continues to rise above the zone temperature setpoint control band and the economizer damper is fully open, the RTRM energizes the third stage of compressor control. If the zone temperature continues to rise above the zone temperature setpoint control band and the economizer damper is fully open, the RTRM energizes the fourth stage of compressor control. If economizing is not possible, the ECA drives the damper to the minimum position setpoint when the indoor fan relay (F) is energized and allows mechanical cooling operation. When the unit is equipped with the optional fan failure switch (FFS), wired to the RTOM, the RTRM will stop all cooling functions and produce an analog output if the fan failure switch (FFS) does not open within 40 seconds after a request for fan operation. When the system is connected to a remote panel, the "SERVICE" LED will flash when this failure occurs.

Economizer Set-Up

Adjusting the minimum position potentiometer located on the unit economizer actuator (ECA) sets the required amount of ventilation air.

Two of the three methods for determining the suitability of the outside air can be selected utilizing the enthalpy potentiometer on the ECA, as described below:

1. Ambient Temperature-Controlling the economizing cycle by sensing the outside air dry bulb temperature. [Table 10](#) lists the selectable dry bulb values by potentiometer setting.
2. Reference Enthalpy-Controlling the economizer cycle by sensing the outdoor air humidity. [Table 10](#) lists the selectable enthalpy values by potentiometer setting. If the outside air enthalpy value is less than the selected value, the economizer is allowed to operate.

3. Comparative Enthalpy-By utilizing a humidity sensor and a temperature sensor in both the return air stream and the outdoor air stream, the unit control processor (RTRM) will be able to establish which conditions are best suited for maintaining the zone temperature, i.e. indoor conditions or outdoor conditions.

The potentiometer located on the ECA is non-functional when both the temperature and humidity sensors are installed.

Table 10. Potentiometer settings

| Potentiometer Setting | Dry Bulb | Enthalpy |
|-----------------------|----------------------|---------------|
| A | 27 Btu/lb (63 kJ/kg) | 73°F (22.8°C) |
| B | 25 Btu/lb (58 kJ/kg) | 70°F (21.1°C) |
| C ^(a) | 23 Btu/lb (53 kJ/kg) | 67°F (19.4°C) |
| D | 22 Btu/lb (51 kJ/kg) | 63°F (17.2°C) |
| E | 19 Btu/lb (44 kJ/kg) | 55°F (12.8°C) |

(a) Factory setting

ReliaTel Control Heating Operation for Cooling Only Units

When the system switch is set to the "Heat" position and the zone temperature falls below the heating setpoint controlband, the RTRM energizes the first stage of electric heat. If the first stage of electric heat cannot satisfy the heating requirement, the RTRM energizes the second stage electric heat if applicable. The RTRM cycles both the first and second stages of heat "On" and "Off" as required to maintain the zone temperature setpoint.

ReliaTel Control Heating Operation for Gas Units

When the system switch is set to the "Heat" position and the zone temperature falls below the heating setpoint controlband, a heat cycle is initiated when the RTRM communicates ignition information to the Ignition module (IGN).

Modulating Gas Heat 2.5:1

Turndown, in a modulating heat unit, when a call for heat is received, the burner will light at full fire (100%). After the burner is lit, the unit controls will monitor the discharge air temperature and modulate the input rate down to match the load.

Ignition Control Module

Two-Stage (IGN) runs self-check (including verification that the gas valve is de-energized). IGN checks the high-limit switches (TC01 and TC02) for normally closed contacts. With power supplied to the ignition module (IGN), the hot surface ignition probe (IP) is Preheated. The gas valve (GV) is energized for a few seconds for trial for ignition, to ignite the burner. Once the burner is ignited, the hot surface ignition probe (IP) is de-energized by the ignition module (IGN) and functions as the flame sensing

device. If the burner fails to ignite, the ignition module will attempt two retries before locking out. The green LED will indicate a lockout by two fast flashes. An ignition lockout can be reset by:

1. Opening for 3 seconds and closing the main power disconnect switch.
2. By switching the "Mode" switch on the zone sensor to "OFF" and then to the desired position.
3. Allowing the ignition control module to reset automatically after one hour. Refer to [Table 11, p. 39](#) for the LED diagnostic definitions.

When the fan selection switch is set to the "Auto" position, the RTRM energizes the indoor fan relay (F) coil approximately 30 seconds after initiating the heating cycle to start the indoor fan motor (IDM). The automatic reset high limit (TCO1), located in the bottom right corner of the burner compartment, protects against abnormally high leaving air temperatures. The automatic reset fan fail limit (TCO2), located in the upper middle section of the indoor fan board, protects against abnormally high heat buildup which could occur because of extended cycling of the high limit (TCO1) or if the indoor fan motor (IDM) fails to operate. Should TCO2 open, the RTRM will energize the indoor fan relay (F) in an attempt to start the fan motor. The RTRM signals that a heat failure has occurred by flashing the "Heat" LED on the zone sensor. There is a green LED located in the Ignition Control Module. Table 11 lists the diagnostics and the status of the LED during the various operating states.

Ignition Control Module Diagnostics

At any time the control is powered, a green LED indicator light shall be lit using the following signal:

Table 11. Ignition module diagnostics

| | |
|------------------------------------|--|
| Steady OFF: | No Power/Failure/Internal Failure |
| Steady ON: | Normal |
| Slow Flash Rate: | Normal, call for heat (¾ second on, ¼ second off). |
| Fast Flash Rate: | Used for error indication only (¼ second off, ¾ second on). |
| Error Code Fast Flash Rate: | |
| 1 Flash | Communication Issue between Refrigeration Module and 3SH control. |
| 2 Flashes | System Lockout: Failed to detect or sustain flame. |
| 3 Flashes | Not implemented. |
| 4 Flashes | High Limit switch protection device open. |
| 5 Flashes | Flame sensed and gas valve not energized or flame sensed and no call for heat. |
| 6 Flashes | Not implemented. |

Note: The pause between groups of fast flashes is approximately two seconds. Additionally, the LED indicator light shall flash for one second at power-up.

Dehumidification

The dehumidification cycle is only permitted above 40 °F and is not permitted during a heating cycle or during a demand for 2nd stage cooling. Otherwise, when an installed zone humidity sensor indicates a relative humidity equal to or greater than the RH set point as adjusted on the ReliaTel Options Module (RTOM), a dehumidification cycle is initiated.

Notes:

- *Dehumidification takes priority over a call for one stage cooling.*
- *Heating or 2 stage cooling takes priority over dehumidification, and a relative humidity sensor takes priority over a humidistat.*

Dehumidification Coil Purge Cycle (for Units with the Dehumidification Option)

On multiple circuit units with Dehumidification/Reheat configured, a purge cycle will be active for compressor reliability. The purpose of this function is to properly distribute refrigerant and lubricant throughout the system by temporarily switching to the unused section of the coil for 3 minutes (purge cycle). The function operates as follows:

1. A purge cycle will be initiated after 90 minutes of accumulated compressor run time in only one mode: cooling or dehumidification, without transitioning to the other mode.
2. A purge cycle will consist of transitioning to the mode that hasn't run in 90 minutes of total compressor operation. The cycle will last for a period of 3 minutes.
3. The 90-minute cycle count will be reset anytime there is a normal transition between cooling and dehumidification. Transitioning from one of these modes to any other mode (off or heat) will not reset the counter.
4. If the purge cycle is a cooling cycle, only the first circuit will be activated. If it is a dehumidification cycle then the normal 2-compressor dehumidification mode cycle will be used.
5. The purge cycle will ignore the Low Ambient Dehumidification lockout feature.
6. A purge cycle takes priority over normal cooling or dehumidification requests, but will discontinue for all high priority lockouts and alarms.

Two-Speed Indoor Fan (Title 24) Control

For units equipped with two-speed indoor fan control, standard unit operation for cooling and heating will continue and all unit functions will operate normally, except for the control of the indoor fan speed. All units configured with any type of heating will heat the supply air and space as normal utilizing full speed indoor fan by

Sequence of Operation

energizing the appropriate outputs. The two-speed indoor fan unit will only utilize two speeds during the cooling operation modes described below.

Cooling Operation

For cooling operation, the unit will operate at Low Fan Speed during Fan Only, Economizer Only, and the first and second stage of compressor unit modes by default. When the unit receives a call for cooling, if the economizer is enabled, the unit will energize the associated Low Speed output and begin to modulate the OA Damper open above minimum position up to 100% as necessary.

By default, once the economizer reaches 100% open, the supply fan will increase to High Speed and remain there. If the OA damper remains at 100% open for 5 minutes, the unit will begin to stage up compressors. Once compressors have started staging up, the economizer is latched at 100% open and the supply fan will remain at High Speed until compressors are de-energized. The unit will stage down compressors for cooling in reverse order that they were staged and the supply fan speed will remain at High Fan Speed until the economizer is no longer required to be 100% open.

If the economizer is not enabled (or the unit does not have an economizer) and the unit receives a call for cooling, the unit will begin to stage compressors. The supply fan will operate at Low Fan Speed during cooling Stage 1 and Stage 2 compressor control and High Fan Speed for cooling Stage 3 and Stage 4 compressor control. The unit will stage down compressors for cooling in reverse order that they were staged and the supply fan speed will decrease to Low Fan Speed when the unit steps down to cooling Stage 2 and will remain at Low Fan Speed until all compressors are off or receives a call for cooling Stage 3.

Once the supply fan is no longer requested ON for Fan Only, Economizer Only, or compressor cooling operations, the supply fan will remain energized at Low Fan Speed for 60 seconds as on traditional units.

For units under Thermostat control, if the economizer is enabled and is being utilized as the first stage of cooling (Y1 active), the supply fan will operate at Low Fan Speed. If the unit receives a Y1+Y2 request, the unit will energize the unit to cooling Stage 2 and increase the supply fan to High Fan Speed. If the economizer is not enabled and the unit receives a Y1 call, cooling Stage 1 compressor control will be energized and the supply fan will operate at Low Fan Speed. If the unit receives a Y1+Y2 request, the RTRM will energize the unit to cooling stage 4 and the supply fan will operate at High Fan Speed.

Economizer Minimum Position Handling for 2-Speed Fan

Due to the low and high speeds of the indoor fan, when the unit is in Fan Only, Cool 1, or Economizer Only and the indoor fan is at low speed, the unit will not be bringing in as much fresh air as normal. By setting a higher minimum damper position this problem could be solved, but that

would mean more fresh air than may be desired when the supply fan is at high speed. To overcome these situations, the control will require the setting of two economizer minimum positions to be used when the fan is at low and high speed to compensate for the lower amount of fresh air at lower fan speeds and the potential for more fresh air than desired at higher fan speeds. These minimum positions will be obtained from the Bldg Design Min Position and DCV Min Position pots on the RTEM. The economizer minimum position that will be utilized while the supply fan is at low speed will be set with the DCV Min Position pot with a range of 0-100% and the minimum position that will be utilized while the supply fan is at high speed will be set with the Building Design Min Position pot with a range of 0-50%. If the Building Design Min Position is set to be higher than the DCV Min Position, the setpoints will be capped at the DCV Min Position and the setpoint for the min position at low and high fan speed will be the DCV Min Position.

Demand Controlled Ventilation Operation

Demand Controlled Ventilation for units with 2-Speed Supply Fans will require an additional module (RTVM) for the 2 additional setpoint potentiometers necessary in order to overcome the non-linear characteristics of the airflow through the outside air damper along with the multiple supply fan speeds.

The new Demand Controlled Ventilation scheme will require the user to select 4 OA Damper Minimum Position setpoints in addition to the Design and DCV CO₂ Setpoints:

1. Design Min Position @ Low Fan Speed Command (RTVM R130)
2. Design Min Position @ High Fan Speed Command (RTEM Design Min)
3. DCV Min Position @ Low Fan Speed Command (RTVM R41)
4. DCV Min Position @ High Fan Speed Command (RTEM DCV Min)

The speed at which the Supply Fan operates will dictate which Design and DCV Minimum Position setpoint is used in the calculation for the OA Damper Minimum Position Target for Demand Controlled Ventilation. All other functionality for Demand Controlled Ventilation will operate as on traditional units.

Low Ambient Operation on Units with 2-Speed Indoor Fan

The indoor fan motor (IDM) will continue to operate at 100% fan speed during this evaporator defrost cycle (EDC) and the compressor and outdoor fan will return to normal operation once the defrost cycle has terminated and the compressor "Off" time delay has been satisfied.

Heating Operation

Standard unit operation for heating will continue on units equipped with a two-speed indoor fan. During heat mode,

all units configured with staged electric or gas heat, modulating gas heat, or reheat/dehumidification will heat and reheat/dehumidify the supply air and space as normal utilizing full speed indoor fan by energizing the RTRM supply fan output.

Failure and Override Modes

- Supply Fan Proving - If there is a supply fan failure condition all outputs associated with the supply fan output control will be de-energized.
- Ventilation Override Mode - For all VOM modes that require supply fan operation (Purge and Pressurize), the supply fan will operate at high speed.
- All failure modes that require the Supply Fan to operate, the Supply Fan will energize at high speed. For instance if the Froststat switch closes, the Supply Fan will operate at high speed.

Single Zone Variable Air Volume (Single Zone VAV) Control

For normal Cooling operation, available cooling capacity will be staged in order to meet the calculated discharge air setpoint between the user selected upper and lower limits. If the current active cooling capacity is controlling the discharge air within the deadband no additional Cooling capacity change will be requested. As the Discharge Air Temperature rises above the deadband the control will request additional capacity as required (additional compressor operation or economizer). As the Discharge Air Temperature falls below the deadband the algorithm will request a reduction in active capacity.

Cooling Operation

If the control determines that there is a need for compressor stages in order to meet the discharge air requirements, once supply fan proving has been made, the unit will begin to stage compressors. As the zone cooling demand continues to increase, if additional capacity is required, the supply fan output will be modulated above minimum speed in order to meet the zone requirements. Note that the supply fan speed will remain at the compressor stage's associated minimum value until the control requires additional capacity to meet the zone demand. As the cooling load in the zone decreases the control will reduce the speed of the fan down to minimum per compressor stage and control the compressor outputs accordingly. As the compressors begin to de-energize, the Supply Fan speed will fall back to the Cooling Stage's associated minimum fan speed but not below. As the load in the zone continues to drop, cooling capacity will be reduced in order to maintain the calculated discharge air setpoint.

Minimum Fan Speeds for Cooling Stages

As the unit begins to stage compressors to meet the cooling demand, the following minimum Supply Fan

Speeds will be utilized for each corresponding Cooling Stage. Note that the Supply Fan Speed will be allowed to ramp up beyond the minimum speed in order to meet the zone cooling demand.

4-Stage Cooling Units

The minimum fan speed for units with 4 stages of DX Cooling will be 50% of the unit's full airflow capacity. At Stages 1 and 2 of DX Cooling the Fan Speed will be at a minimum of 50% and at Stage 3 and 4 of DX Cooling the Fan Speed will be at a minimum of 72%.

Economizer Cooling

During normal Economizer Cooling, the fan speed will operate at its minimum. However, if the economizer is able to meet the demand alone, due to desirable ambient conditions, the supply fan speed will be allowed to increase above the minimum prior to utilizing mechanical cooling.

Note: *The economizer Enable/Disable decisions will be made based on the previous sections; however, the economizer control point will now be variable based on the zone cooling demand.*

Demand Controlled Ventilation

Units configured for SZVAV and Demand Controlled Ventilation (CO₂ sensor value available) require a new control scheme comprised of 2 existing schemes that have been traditionally mutually exclusive; DCV and OA CFM Compensation. Units configured with DCV will invoke the new Demand Controlled Ventilation scheme which allows variable Bldg. Design and DCV Minimum Positions and OA Damper Position Target setpoints based on the supply fan speed and space CO₂ requirements.

Economizer Damper Position Set-Up with DCV

This new scheme will require the setting of 5 OA Damper position setpoints; 3 more than on non-SZ VAV. These new setpoints are located on the RTVM module:

1. Design Min Position @ Minimum Fan Speed Command (RTVM R130)
2. Design Min Position @ Middle Fan Speed Command (RTVM R136)
3. Design Min Position @ Full Fan Speed Command (RTEM Design Min Position)
4. DCV Min Position @ Minimum Fan Speed Command (RTVM R41)
5. DCV Min position @ Full Fan Speed Command (RTEM DCV Min Position)

As the supply fan speed command varies between minimum and maximum, the Building Design and DCV Minimum Position Targets will be calculated between the user selected setpoints based on the instantaneous supply fan speed. The Bldg. Design and DCV Minimum Position Targets will be used to calculate the Active OA Damper

Sequence of Operation

Minimum Position Target, as on traditional units, based on the Space CO₂ relative to the active Design and DCV CO₂ setpoints.

By default, the Design Minimum Position schedule will be a linear line through all user selectable Design Minimum Position setpoints. The user will have the ability to set the Design Minimum Position at Middle fan speed command to a point that would be lower than the calculated linear line between the Design Minimum Position setpoints at 0% and 100% fan speed command in order to compensate for the non-linear outside airflow through the fan and damper modulation range. However, if the Design Minimum Position at Middle fan speed command is set to a point that would be higher than the calculated linear line between the Design Minimum Position setpoints at Minimum and Full fan speed command, the minimum position will be limited to the point that would make the Design Minimum Position schedule linear.

Provisions have been made in Service Test Mode to allow for proper damper minimum position setup:

1. To set the Design and DCV Minimum Position setpoints at Minimum Fan Speed, set the unit to operate at Step 1 (Fan ON) or Step 2 (Economizer Open) and make the proper adjustments.
2. To set the Design Minimum Position setpoint at Middle Fan Speed, set the unit to operate at Step 3 (Cool 1) and make the proper adjustment.
3. To set the Design and DCV Minimum Position setpoints at Full Fan Speed, set the unit to operate at Step 4 (Cool 2) and make the proper adjustments.

Economizer Damper Position Set-Up without DCV

For units not configured with DCV (no CO₂ sensor value available), additional minimum position setpoints to increase outdoor airflow accuracy will be supported. The operation will be similar to OA CFM Compensation on Traditional VAV units with the addition of a Design Minimum Position setpoint at Middle Fan Speed Command. The following setpoint potentiometers will be used on the RTEM:

1. Design Min at Minimum Fan Speed Command (RTEM DCV Min)
2. Design Min at Middle Fan Speed Command (RTEM DCV Setpoint LL)
3. Design Min at Full Fan Speed Command (RTEM Design Min)

The controller will calculate the active OA Damper Minimum position between the user-selected setpoints based on the supply fan speed command. By Default, the Design Minimum Position schedule will be a linear line through all user selectable Design Minimum Position setpoints. As with Demand Controlled Ventilation, if the Design Minimum Position at Middle fan speed command is set to a point that would be higher than the calculated linear line between the Design Minimum Position

setpoints at Minimum and Maximum fan speed command, the minimum position will be limited to the point that would make the Design Minimum Position schedule linear.

Provisions have been made in Service Test Mode to allow for proper damper minimum position setup:

1. To set the Design Minimum Position setpoint at Minimum Fan Speed, set the unit to operate at Step 1 (Fan ON) or Step 2 (Economizer Open) and make the proper adjustment.
2. To set the Design Minimum Position setpoint at Middle Fan Speed, set the unit to operate at Step 3 (Cool 1) and make the proper adjustment.
3. To set the Design Minimum Position setpoint at Full Fan Speed, set the unit to operate at Step 4 (Cool 2) and make the proper adjustment.

Heating Operation

Heating operation on units configured with Single Zone VAV control will utilize two separate control methodologies based on heating configurations. For all "Staged" Heating types (Electric and Gas), the unit will utilize 100% full airflow during all active heating periods like traditional Constant Volume units. For Modulating Gas heat units, the unit will have the ability to control the discharge air temperature to the calculated discharge air heating setpoint in order to maintain the Zone Temperature to the Zone Heating setpoint.

Staged Heating Operation

For units configured with Staged Heat once the control determines that there is an active heating capacity request, the unit will energize the Supply Fan and ramp up to full speed. The control methodology during Active Heating on units configured with Staged Heat types will be identical to traditional Constant Volume units; heating stages will be energized/de-energized to meet the Zone Heating demand.

Note: All electric and gas Heat staging sequences will be identical to Constant Volume unit staging sequences.

Modulating Heat Operation with SZVAV Heating

Units configured with Modulating Gas Heat will utilize true Single Zone VAV control in the same manner as during Active Cooling.

Heating Sequence

Once the unit control determines that there is a space heating demand, the unit will transition into zone heating. Once the Discharge Air Temperature falls below the calculated discharge air temperature setpoint, the unit will initiate the Modulating Heat output request and control the supply fan at minimum speed. At this point, the Modulating Heat output will be controlled to maintain the discharge air temperature requirements and the supply

fan speed will be controlled between 63%-100% to meet the zone heating requirements.

As the heating load in the zone decreases the fan speed will decrease down to minimum (63%) and control the modulating heat output as necessary to meet the discharge air heating requirements. As the load in the zone continues to drop the fan speed will be maintained at this minimum airflow and the modulating heat output will be controlled accordingly.

Low Ambient Operation

The indoor fan motor (IDM) will operate at 100% fan speed during this evaporator defrost cycle (EDC) and the compressor and outdoor fan will return to normal operation once the defrost cycle has terminated and the compressor "Off" time delay has been satisfied.

Dehumidification

Entering Dehumidification

At startup a zone heating or cooling demand will prevent dehumidification operation as on a non-Single Zone VAV unit. At this point the unit will perform normal sensible cooling or heating control until the respective setpoint is satisfied.

After startup, the unit will monitor the unit conditions to determine when to enter and leave dehumidification mode. As long as the unit is not actively heating or actively cooling with more than half the unit design mechanical cooling capacity and it has not been disabled due to the Override limits described below, dehumidification mode will be allowed.

Dehumidification Overrides

Sensible cooling or heating control overrides dehumidification control. Any heating request will terminate dehumidification control. If heating is active at the time a call for dehumidification control is received the heating operation must complete and an additional 5 minutes from the time heat is terminated must elapse before dehumidification will be allowed. Dehumidification will also be disabled if any of the functional disables that apply to CV or traditional VAV have gone active.

Purge Mode (Comfort and Dehumidification)

Purge cycle operation will operate identically to Purge on non-Single Zone VAV Dehumidification units; if the Reheat Circuit operates in one mode (dehumidification or cooling) for a cumulative 60 minutes the unit will initiate a 3-minute Purge cycle with all compressors energized.

During an active Purge Cycle the Supply Fan Speed will operate at the appropriate speed based on the active compressor step. If a dehumidification purge is initiated, the unit will run at 72%, if performing a cooling purge the supply fan will track based on the appropriate minimum speed for the associated number of compressors energized. After the Purge Cycle is complete, the Supply

Fan will be released to normal control based on the Cooling/Dehumidification demand.

Dehumidification - Humidistat Operation

A humidistat input located on the Options module will be supported as on non-SZ VAV.

Failure and Override Modes

Certain failure and overriding conditions require special handling of the Supply Fan Speed on units configured with Single Zone VAV. See below for a list of these conditions:

- Supply Fan Proving Failure - If a Supply Fan Proving failure is detected, the Supply Fan will be de-energized after 40s of run time and the Fan Speed output will go to 0 Vdc (0%).
- Ventilation Override Mode - If a VOM goes active in which the Supply Fan is commanded ON (Purge, Pressurize, etc.), the Supply Fan will be energized and the Fan Speed output will ramp to 100%.
- Zone Temperature Sensor Failure - If the Active Zone Temperature input goes out of range, the unit will discontinue all Heating, Cooling, and Dehumidification operation.
- Supply Air Temperature Sensor Failure - If the Supply Air Temperature input goes out of range, the unit will revert back to Full Airflow, Traditional CV control. The unit will call out a Supply Air Temperature Sensor Failure Alarm, the RTRM System LED will flash the 2-blink error code, and the Zone Sensor Heat (Modulating Heat Only) and Cool LEDs will flash.
- Froststat Failure - If a Froststat failure occurs, all active Heating, Cooling, and Dehumidification will be de-energized immediately and the Supply Fan will ramp up to 100%.
- Heat Failure (High Temp. Limit Trip) - If a unit configured with Gas Heat has a High Temp. Limit trip, the Supply Fan will be requested to remain ON and the Fan Speed output will ramp to full speed.

Variable Air Volume Applications (Traditional VAV)

Supply Air Temperature Control - Occupied Cooling and Heating

The RTRM is designed to maintain a selectable supply air temperature of 40°F to 90°F with a +/- 3.5°F deadband.

Note: To reduce the risk of coil freezing, it is not recommended to set the supply air temperature below 50°F.

In cooling, if supply air temperature is more than 3.5 degrees warmer than the selected temperature, a stage of cooling will be turned "On" (if available). Then if the supply air temperature is more than 3.5 degrees cooler than the selected temperature, a stage of cooling will be

Sequence of Operation

turned "Off". At very low airflows the unit may cycle stages "On" and "Off" to maintain an average discharge air temperature outside the 7 degree deadband.

If the unit has modulating heat, the unit can be made to do discharge heating with VAV control. This is done by placing a contact closure across the "Changeover Input" on the RTAM. During this mode, the unit will heat to the Supply Air Heating Setpoint +/- 3.5°F. During low load or low airflow conditions the actual temperature swing of the discharge air will likely be greater.

The RTRM utilizes a proportional and integral control scheme with the integration occurring when the supply air temperature is outside the deadband. As long as the supply air temperature is within the setpoint deadband, the system is considered to be satisfied and no staging up or down will occur.

Supply Air Temperature Control with an Economizer

The economizer is utilized to control the supply air cooling at +1.5°F around the supply air temperature setpoint range of 40°F and 90°F providing the outside air conditions are suitable. While economizing, the mechanical cooling is disabled until the economizer dampers have been fully open for three minutes. If the economizer is disabled due to unsuitable conditions, the mechanical cooling will cycle as though the unit had no economizer.

VHR Relay Output

During unoccupied mode, daytime warm-up (DWU) and morning warm-up (MWU) the VFD will open to 100%. All VAV boxes must be opened through an ICS program or by the VHR wired to the VAV boxes. The RTRM will delay 100% fan operation approximately 6.5 minutes when switching from occupied cooling mode to a heating mode.

Zone Temperature Control without a Night Setback Panel or ICS - Unoccupied Cooling

When a field supplied occupied/unoccupied switching device is connected between RTRM J6-11 and RTRM J6-12, both the economizer and the mechanical cooling will be disabled.

Zone Temperature Control without a Night Setback Panel or ICS - Unoccupied Heating

When a field supplied occupied/unoccupied switching device is connected between RTRM J6-11 and J6-12 and DWU is enabled, the zone temperature will be controlled at 10°F below the Morning Warm-up setpoint, but not less than 50°F, by cycling one or two stages of either gas or electric heat, whichever is applicable.

Morning Warm-up (MWU) Control

Morning Warm-up is activated if the zone temperature is at least 1.5°F below the MWU setpoint whenever the system switches from Unoccupied to Occupied status. The MWU setpoint may be set from the unit mounted potentiometer or a remotely mounted potentiometer. The setpoint ranges are from 50°F to 90°F. When the zone temperature meets or exceeds the MWU setpoint, the unit will switch to the "Cooling" mode. The economizer will be held closed during the morning warm-up cycle.

Daytime Warm-up (DWU) Control

Daytime Warm-up is applicable during occupied status and when the zone temperature is below the initiation temperature. It can be activated or deactivated through ICS or a night setback zone sensor. If ICS or a night setback zone sensor is not utilized, DWU can be activated by setting the DWU enable DIP switch (RTAM) to ON and supplying a valid morning warm-up setpoint. The unit is shipped with a Morning Warm-up setpoint configured and the Daytime Warm-up function is activated (switch on). Opening the DWU enable switch will disable this function. If the system control is local, the DWU initiation setpoint is 3°F below the Morning Warm-up setpoint. The termination setpoint is equal to the Morning Warm-up setpoint. If the system control is remote (Tracer™), the DWU setpoint is equal to the Tracer Occupied heating setpoint. The initiation and termination setpoints are selectable setpoints designated by Tracer. When the zone temperature meets or exceeds the termination setpoint while the unit is in an Occupied, "Auto" Mode or switched to the "Cooling" Mode, the unit will revert to the cooling operation. If an Occupied "Heating" Mode is selected, the unit will only function within the DWU perimeters until the system is switched from the "Heat" Mode or enters an Unoccupied status.

Note: When a LCI is installed on a VAV unit, the MWU setpoint located on the RTAM board is ignored. The MWU and DWU setpoints come from the higher priority LCI-R DAC.

Table 12. Variable air volume mode operation

| System Mode | | Fan "Auto" | Fan "On" |
|-------------|------------|-----------------------------------|-------------------------------------|
| Heat | DWU Active | DWU ² | DWU ² |
| | DWU Off | Off ⁴ | VAV Heating ⁴ |
| Cool | | VAV Cooling ¹ | VAV Cooling ¹ |
| | | | |
| Auto | DWU Active | DWU or Cooling ^{1,2,3,4} | DWU or Cooling ^{1,2,3,4} |
| | DWU Off | VAV Cooling ¹ | VAV Cooling or Heating ¹ |
| Off | | Off ⁴ | Off ⁴ |

Notes:

1. If Cooling is selected the supply fan will run continuously. If VAV Heating is activated the supply fan will run continuously.
2. If Daytime Warmup is Activated, the supply fan will run continuously.
3. Auto changeover between Cooling and Daytime Warmup depends upon the DWU initiate setpoint.
4. The fan will be Off any time the system selection switch is "Off".

Supply Duct Static Pressure Control

The supply duct static pressure is measured by a transducer with a 0.25 to 2.125 Vdc proportional output which corresponds to an adjustable supply duct static pressure of 0.3" w.c. to 2.5" w.c. respectively with a deadband adjustment range from 0.2" w.c. to 1.0" w.c. The setpoint is adjustable on the RTAM Static Pressure Setpoint potentiometer or through ICS.

Example:

Supply Duct Static setpoint = 2.0" w.c. (RTAM)

Deadband = 0.2" w.c. (RTAM)

Duct Static Control Range = 1.9" w.c. to 2.1" w.c.

Mechanical Cooling with an Economizer

The economizer is utilized to control the zone temperature when the outside air conditions are suitable. The method used to determine economizer effectiveness, depending on the available data, is described below in descending order of complexity.

Table 13. Economizer effectiveness

| Method used to determine economizer effectiveness | Required |
|---|------------------------------------|
| Comparative Enthalpy | OAT, OAH, RAT, RAH |
| Reference Enthalpy | OAT, OAH |
| Reference Dry Bulb | OAT |
| Unable to determine effectiveness | OAT data is invalid or unavailable |

The most sophisticated method available is always used. Two of the three methods for determining the suitability of the outside air can be selected utilizing the potentiometer on the Economizer Actuator, as described below:

1. Ambient Temperature - controlling the economizing cycle by sensing the outside air dry bulb temperature. [Table 14](#) lists the selectable dry bulb values by potentiometer setting.
2. Reference Enthalpy - controlling the economizer cycle by sensing the outdoor air humidity. [Table 14](#) lists the selectable enthalpy values by potentiometer setting. If the outside air enthalpy value is less than the selected value, the economizer is allowed to operate.

Table 14. Economizer configuration

| Selection | Dry Bulb | Enthalpy Value |
|-----------|----------|----------------|
| A | 73°F | 27 BTU/LB Air |
| B | 70°F | 25 BTU/LB Air |
| C | 67°F | 23 BTU/LB Air |
| D | 63°F | 22 BTU/LB Air |
| E | 55°F | 19 BTU/LB Air |

3. Comparative Enthalpy - By utilizing a humidity sensor and a temperature sensor in both the return air stream and the outdoor air stream, the economizer will be able to establish which conditions are best suited for

maintaining the zone temperature, i.e., indoor conditions or outdoor conditions.

Off Mode

This mode is set at the zone sensor or by ICS. During this status, no heating, ventilation, or mechanical cooling is being performed. When switching the "System" selector to the "Off" mode from any other mode, any diagnostic data and diagnostic indication signal will be retained as long as the system remains in the "Off" status. Switching the "System" selector from the "Off" mode back to any other mode of operation will reset all diagnostics.

Heating Operation

Heating operation on units configured with Traditional Multi-Zone VAV control will utilize two separate control methodologies based on heating configurations. For all "Staged" Heating types (Electric and Gas), the unit will utilize 100% full airflow during all active heating periods like traditional Constant Volume units. If the unit has modulating heat, the unit can be made to do discharge heating with VAV control. This is done by placing by placing a contact closure across the "Changeover Input" on the RTAM. During this mode, the unit will heat to the Supply Air Heating Setpoint ± 3.5°F. During low load or low airflow conditions the actual temperature swing of the discharge air will likely be greater.

Zone Temperature - Unoccupied Heating

While a building is in an unoccupied period as designated by a remote panel with night setback or ICS, the necessary heating capacity will be controlled to maintain the zone temperature to within the unoccupied setpoint deadband. For traditional VAV systems, the VFD will operate at 100% during this mode. It will be necessary to drive VAV boxes to their maximum position through ICS programming or the factory provided VHR relay. For Modulating Gas Heat units, Full Airflow is not required but can be enabled by connecting the changeover mode input J5-1 and J5-2 on the RTAM module. For all Staged Heating types, the Supply Fan will be controlled at maximum fan speed during active heating operation as during Occupied periods.

Gas Heat Control

The ignition sequence and timing are provided by a separate heat control module. The RTRM only provides the heating outputs to initiate 1st and 2nd stages and control the combustion blower relay. Both stages of the furnace will start and operate for one minute and then cycle back if only one stage is required. Units with modulating heat capabilities will light on high fire for one minute and then modulate to the appropriate heating rate for the building load present.

Electric Heat Control

The RTRM provides two heating outputs for 1st and 2nd stages that will be controlled with at least a 10 seconds

Sequence of Operation

delay between each stage. When the fan selection switch is in the "AUTO" mode, the fan will start approximately 1 second before the 1st heater stage is activated. The fan and heater will cycle off after the heating setpoint has been satisfied. Once the Zone Heating requirements have been satisfied, the fan and heat outputs will be controlled off.

Constant Volume or Variable Air Volume Applications (SZVAV or Traditional)

Clogged Filter Option

The unit mounted clogged filter switch monitors the pressure differential across the return air filters. It is mounted in the indoor section and is connected to the RTOM. The clogged filter switch is normally open and will automatically close when the pressure differential across the filters falls below the clogged filter setpoint. The RTOM will generate a SERVICE diagnostic that will be sent to the zone sensor or remote panel when the clogged filter switch has been closed for at least 2 minutes during supply fan operation. The system will continue to operate regardless of the status of the clogged filter switch.

Ventilation Override

Note: Applying 24 volts to one of the three Ventilation Override Inputs manually activates ventilation override. One input is provided to request the Pressurize Mode, the second input the Purge Mode, and the third input the Exhaust Mode.

When the Pressurize Mode is selected, activating Ventilation Override will cause the supply fan to run, the economizer to open to 100%, the exhaust fan to turn (remain) off, or the VFD to run at full speed (SZ VAV and Traditional VAV), and the VAV boxes to fully open.

When Purge is selected, activating Ventilation Override will cause the supply fan to run, the economizer to open to 100%, the exhaust fan to run, or the VFD to run at full speed (SZ VAV or Traditional VAV), and the VAV boxes to fully open.

When Exhaust is selected, activating Ventilation Override will cause the supply fan to turn off, the economizer to close to 0%, the exhaust fan to run (exhaust damper at 100% if configured for Statitrac), or the VFD to stop, and the VAV boxes to operate normally.

If more than one mode is requested at the same time, the Pressurize request will have priority followed by Purge. When any Ventilation Override Mode is active, all heating and cooling is turned off. For the case where the unit is required to turn off, the Emergency Stop input is used. The ICS can also initiate any ventilation override mode.

Table 15 lists the sequence of events within the system for each ventilation mode. Refer to the unit wiring diagram for contact switching and wiring.

Note: Fresh air tracking will not work with VOM.

Table 15. Ventilation override sequence

| Affected Function | Mode and Priority | | |
|-------------------|-------------------|-------------------|------------------------|
| | Pressurize | Purge | Exhaust ^(a) |
| | 1 | 2 | 3 |
| Heat/Cool | off | off | off |
| VFD | full speed | full speed | full speed |
| Supply Fan | on | on | off |
| Exhaust Fan | off | on ^(b) | on |
| Economizer | open | open | closed |
| VAV Boxes | forced open | forced open | normal operation |

(a) Exhaust mode 3 is not available with the tracking power exhaust option.

(b) For units configured with the Statitrac option, the Exhaust Damper will open during Ventilation Override modes that request the exhaust fan to operate.

Emergency Stop

When this binary input is opened, all outputs are immediately turned off and the system will not be allowed to restart until the binary input is closed for approximately 5 seconds minimum. The shutdown is communicated to Tracer™ if applicable and the Heat and Cool LED outputs (RTRM J6-7 and J6-8) will blink at a nominal rate of 1 blink per second.

Phase Monitor

The Phase Monitor is a 3 phase line monitor module that protects against phase loss, phase reversal and phase unbalance. It is intended to protect compressors from reverse rotation. It has an operating input voltage range of 190-600 VAC, and LED indicators for ON and FAULT. There are no field adjustments and the module will automatically reset from a fault condition.

Low Pressure Control

This input incorporates the low pressure cutout of each refrigeration circuit and can be activated by opening a field supplied contact.

If this circuit is open before a compressor(s) is started, neither compressor in that circuit will be allowed to operate.

Anytime this circuit is opened for 5 continuous seconds, the compressor(s) in that circuit are turned off immediately. The compressor(s) will not be allowed to restart for a minimum of 3 minutes.

If four consecutive open conditions occur during the first three minutes of operation, the compressor(s) in that circuit will be locked out, a diagnostic communicated to Tracer, and a manual reset will be required to restart the compressor(s).

High Pressure Cutout and Temperature Discharge Limit

The high pressure controls and temperature discharge limit are wired in series between the compressor outputs on the RTRM and the compressor contactors. If the high pressure safety or temperature discharge limit opens, the compressor(s) on the affected circuit is locked out. If the compressor output circuit is opened four consecutive times during compressor operation, the RTRM will generate a manual reset lockout.

Lead/Lag Control

Lead/Lag is a selectable input located on the RTRM. The RTRM is configured from the factory with the Lead/Lag control disabled. To activate the Lead/Lag function, simply cut the wire that connects J3-8 to common at the RTRM Lead/Lag input. When it is activated, each time the designated lead compressor(s) is shut off due to the load being satisfied, the lead compressor or refrigeration circuit switches. When the RTRM is powered up, i.e. after a power failure, the control will default to the number one compressor.

Coil Frost Protection

The Froststat™ control monitors the evaporator coil temperature to prevent the evaporator from freezing due to low operating temperatures whenever there is a demand for cooling. When a closed circuit has occurred for 5 seconds minimum, the RTRM turns off all of the cooling outputs. The Supply Fan will be held "On" until the Froststat has been opened for 5 continuous seconds or for 60 seconds after the last compressor was shut "Off", whichever is the longest. The compressor shutdown is communicated to Tracer, if applicable. There is no local diagnostic for this condition.

Maintenance

Make sure all personnel are standing clear of the unit before proceeding. The system components will start when the power is applied.

Fan Belt Adjustment - Belt Drive Units

⚠ WARNING

Rotating Components!

The following procedure involves working with rotating components. Disconnect all electric power, including remote disconnects before servicing. Follow proper lockout/tagout procedures to ensure the power can not be inadvertently energized. Failure to disconnect power before servicing could result in rotating components cutting and slashing technician which could result in death or serious injury.

The fan belts must be inspected periodically to assure proper unit operation.

Replacement is necessary if the belts appear frayed or worn. Units with dual belts require a matched set of belts to ensure equal belt length.

When removing or installing the new belts, do not stretch them over the sheaves. Loosen the belts using the belt tension adjustment bolts on the motor mounting base.

Once the new belts are installed, using a Browning or Gates tension gauge (or equivalent) illustrated in [Figure 29, p. 48](#); adjust the belt tension as follows;

1. To determine the appropriate belt deflection;
 - a. Measure the center-to-center shaft distance (in inches) between the fan and motor sheaves.
 - b. Divide the distance measured in Step 1a by 64; the resulting value represents the amount of belt deflection that corresponds to the proper belt tension.
2. Set the large O-ring on the belt tension gauge at the deflection value determined in Step 1b.
3. Set the small O-ring at zero on the force scale of the gauge plunger.
4. Place the large end of the gauge at the center of the belt span; then depress the gauge plunger until the large O-ring is even with the top of the next belt or even with a straightedge placed across the fan and motor sheaves. Refer to [Figure 29, p. 48](#).
5. Remove the belt tension gauge. The small O-ring now indicates a number other than zero on the plunger's force scale. This number represents the force (in pounds) required to give the needed deflection.
6. Compare the "force" scale reading (Step 5) with the appropriate "force" value listed in [Table 16, p. 48](#). If the "force" reading is outside the range, readjust the belt tension.

Note: Actual belt deflection "force" must not exceed the maximum "force" value shown in [Table 16, p. 48](#).

Table 16. Belt tension measurement and deflection ranges

| Belts Cross Section | Small P.D Range | Deflection Force (Lbs.) | | | | | |
|---------------------|-----------------|-------------------------|-------|-----------|--------|-----------------------|-------|
| | | Super Gripbelts | | Gripnotch | | Steel Cable Gripbelts | |
| | | Min. | Max. | Min. | Max. | Min. | Max. |
| A | 3.0 - 3.6 | 3 | 4 1/2 | 3 7/8 | 5 1/2 | 3 1/4 | 4 |
| | 3.8 - 4.8 | 3 1/2 | 5 | 4 1/2 | 6 1/4 | 3 3/4 | 4 3/4 |
| | 5.0 - 7.0 | 4 | 5 1/2 | 5 | 6 7/8 | 4 1/4 | 5 1/4 |
| B | 3.4 - 4.2 | 4 | 5 1/2 | 5 3/4 | 8 | 4 1/2 | 5 1/2 |
| | 4.4 - 5.6 | 5 1/8 | 7 1/8 | 6 1/2 | 9 1/8 | 5 3/4 | 7 1/4 |
| | 5.8 - 8.8 | 6 3/8 | 8 3/4 | 7 3/8 | 10 1/8 | 7 | 8 3/4 |

7. Recheck the belt tension at least twice during the first 2 to 3 days of operation. Belt tension may decrease until the new belts are "run in".

Figure 29. Belt tension gauge

$$\text{Deflection} = \frac{\text{Belt Span (in)}}{64}$$

$$\text{Deflection} = \frac{\text{Belt Span (mm)}}{152}$$

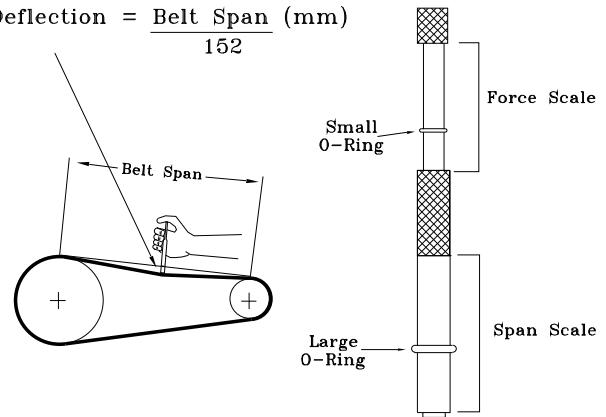

Monthly Maintenance

⚠ WARNING

Hazardous Voltage!

Disconnect all electric power, including remote disconnects before servicing. Follow proper lockout/tagout procedures to ensure the power can not be inadvertently energized. Failure to disconnect power before servicing could result in death or serious injury.

Before completing the following checks, turn the unit OFF and lock the main power disconnect switch open. Failure to disconnect power before servicing can cause severe personal injury or death.

Filters

Inspect the return air filters. Clean or replace them if necessary. Refer to the unit Service Facts for filter information.

Condensate Overflow Switch

During maintenance, the switch float (black ring) must be checked to ensure free movement up and down.

Return Air Smoke Detector Maintenance

Airflow through the unit is affected by the amount of dirt and debris accumulated on the indoor coil and filters. To insure that airflow through the unit is adequate for proper sampling by the return air smoke detector, complete adherence to the maintenance procedures, including recommended intervals between filter changes, and coil cleaning is required.

Periodic checks and maintenance procedures must be performed on the smoke detector to insure that it will function properly. For detailed instructions concerning these checks and procedures, refer to the appropriate section(s) of the smoke detector Installation and Maintenance Instructions provided with the literature package for this unit.

Cooling Season

- Check the unit's drain pans and condensate piping to ensure that there are no blockages.
- Inspect the evaporator and condenser coils for dirt, bent fins, etc. If the coils appear dirty, clean them according to the instructions described in "Coil Cleaning" later in this section.
- Manually rotate the condenser fan(s) to ensure free movement and check motor bearings for wear. Verify that all of the fan mounting hardware is tight.
- Inspect the F/A-R/A damper hinges and pins to ensure that all moving parts are securely mounted. Keep the blades clean as necessary.
- Verify that all damper linkages move freely; lubricate with white grease, if necessary.
- Check supply fan motor bearings; repair or replace the motor as necessary.
- Check the fan shaft bearings for wear. Replace the bearings as necessary.
- Check the supply fan belt. If the belt is frayed or worn, replace it. Refer to the "Fan Belt Adjustment" section for belt replacement and adjustments.
- Verify that all wire terminal connections are tight.
- Remove any corrosion present on the exterior surfaces of the unit and repaint these areas.
- Generally inspect the unit for unusual conditions (e.g., loose access panels, leaking piping connections, etc.)
- Make sure that all retaining screws are reinstalled in the unit access panels once these checks are complete.

- With the unit running, check and record the: ambient temperature; compressor suction and discharge pressures (each circuit); superheat (each circuit);

Record this data on an "operator's maintenance log" like the one shown in [Table 17, p. 50](#). If the operating pressures indicate a refrigerant shortage, measure the system superheat. For guidelines, refer to the "Compressor Start-Up" section.

Note: *Do not release refrigerant to the atmosphere! If adding or removing refrigerant is required, the service technician must comply with all federal, state and local laws.*

Heating Season

- Inspect the unit's air filters. If necessary, clean or replace them.
- Check supply fan motor bearings; repair or replace the motor as necessary.
- Inspect both the main unit control panel and heat section control box for loose electrical components and terminal connections, as well as damaged wire insulation. Make any necessary repairs.
- Verify that the electric heat system operates properly. Check the continuity of each temperature limit to ensure full heating capacity. If the unit has experienced a fan, fan motor or belt failure, one or more of the single operation limits may have opened and the limit(s) may need to be replaced.

Coil Cleaning

Regular coil maintenance, including annual cleaning, enhances the unit's operating efficiency by minimizing: compressor head pressure and amperage draw; evaporator water carryover; fan brake horsepower, due to increase static pressure losses; airflow reduction.

At least once each year, or more often if the unit is located in a "dirty" environment, clean the evaporator and condenser coils using the instructions outlined below. Be sure to follow these instructions as closely as possible to avoid damaging the coils.

To clean refrigerant coils, use a soft brush and a sprayer (either a garden pump-up type or a high-pressure sprayer). A high-quality detergent is also required; suggested brands include "SPREX A.C.", "OAKITE 161", "OAKITE 166" and "COILOX". If the detergent selected is strongly alkaline (ph value exceeds 8.5), add an inhibitor.

1. Remove enough panels from the unit to gain access to the coil. Remove the access panel from the roof located next to the rear condenser fan.
2. Protect all electrical devices such as motors and controllers from any over spray.
3. Straighten any bent coil fins with a fin comb.
4. Mix the detergent with water according to the manufacturer's instructions. If desired, heat the

Maintenance

solution to 150° F maximum to improve its cleansing capability.

⚠ WARNING

Hazardous Pressures!

If a heat source is required to raise the tank pressure during removal of refrigerant from cylinders, use only warm water or heat blankets to raise the tank temperature. Do not exceed a temperature of 150°F. Do not, under any circumstances apply direct flame to any portion of the cylinder. Failure to follow these safety precautions could result in a sudden rise of pressure possibly resulting in a violent explosion which could result in death or serious injury.

Do not heat the detergent-and-water solution above 150°F. Hot liquids sprayed on the exterior of the coil will raise the coil's internal pressure and may cause it to burst. Failure to follow proper procedures can result in personal illness or injury or severe equipment damage.

5. Pour the cleaning solution into the sprayer. If a high-pressure sprayer is used:
 - a. do not allow sprayer pressure to exceed 600 psi.
 - b. the minimum nozzle spray angle is 15 degrees.
 - c. maintain a minimum clearance of 6" between the sprayer nozzle and the coil.
 - d. spray the solution perpendicular (at 90 degrees) to the coil face.
6. Spray the leaving-airflow side of the coil first; then spray the opposite side of the coil. Allow the cleaning solution to stand on the coil for five minutes.
7. Rinse both sides of the coil with cool, clean water.
8. Inspect both sides of the coil; if it still appears to be dirty, repeat Steps 6 and 7.
9. Reinstall all of the components and panels removed in Step 1 and any protective covers installed in step 2.
10. Restore the unit to it's operational status and check system operation.

Final Process

For future reference, you may find it helpful to record the unit data requested below in the blanks provided.

(1) Complete Unit Model Number:

(2) Unit Serial Number:

(3) Wiring Diagram Numbers (from unit control panel):

— schematic(s)

— connection(s)

Table 17. Sample maintenance log

| Date | Refrigerant Circuit #1 | | | | | | Refrigerant Circuit #2 | | | | |
|------|--------------------------|------------------|---------------------------|-------------------------------|----------------|--------------|------------------------|---------------------------|-------------------------------|----------------|--------------|
| | Current Ambient temp F/C | Compr. Oil Level | Suction Pressure Psig/kPa | Dischcharge Pressure Psig/kpa | Super heat F/C | Sub cool F/C | Compr. Oil Level | Suction Pressure Psig/kPa | Dischcharge Pressure Psig/kpa | Super heat F/C | Sub cool F/C |
| | | | | | | | | | | | |
| | | | | | | | | | | | |
| | | | | | | | | | | | |
| | | | | | | | | | | | |
| | | | | | | | | | | | |
| | | | | | | | | | | | |
| | | | | | | | | | | | |

Troubleshooting

⚠ WARNING

Hazardous Service Procedures!

The maintenance and troubleshooting procedures recommended in this section of the manual could result in exposure to electrical, mechanical or other potential safety hazards. Always refer to the safety warnings provided throughout this manual concerning these procedures. Unless specified otherwise, disconnect all electrical power including remote disconnect and discharge all energy storing devices such as capacitors before servicing. Follow proper lockout/tagout procedures to ensure the power can not be inadvertently energized. When necessary to work with live electrical components, have a qualified licensed electrician or other individual who has been trained in handling live electrical components perform these tasks. Failure to follow all of the recommended safety warnings provided, could result in death or serious injury.

ReliaTel Controls

The RTRM has the ability to provide the service personnel with some unit diagnostics and system status information.

Before turning the main power disconnect switch "Off", follow the steps below to check the ReliaTel Refrigeration Module (RTRM). All diagnostics & system status information stored in the RTRM will be lost when the main power is turned "Off".

To prevent injury or death from electrocution, it is the responsibility of the technician to recognize this hazard and use extreme care when performing service procedures with the electrical power energized.

1. Verify that the Liteport LED on the RTRM is burning continuously. If the LED is lit, go to Step 3.
 2. If the LED is not lit, verify that 24 VAC is presence between J1-1 and J1-2. If 24 Vac is present, proceed to Step 3. If 24 Vac is not present, check the unit main power supply, check transformer (TNS1). Proceed to Step 3 if necessary.
 3. Utilizing "Method 1" or "Method 2" in the "System Status Checkout Procedure" section, check the following:
 - System status
 - Heating status
 - Cooling status
- If a System failure is indicated, proceed to Step 4. If no failures are indicated, proceed to Step 5.
4. If a System failure is indicated, recheck Steps 1 and 2. If the LED is not lit in Step 1, and 24 VAC is present in Step 2, the RTRM has failed. Replace the RTRM.
 5. If no failures are indicated, use one of the TEST mode procedures described in the "Unit Start-Up" section to

start the unit. This procedure will allow you to check all of the RTRM outputs, and all of the external controls (relays, contactors, etc.) that the RTRM outputs energize, for each respective mode. Proceed to Step 6.

6. Step the system through all of the available modes, and verify operation of all outputs, controls, and modes. If a problem in operation is noted in any mode, you may leave the system in that mode for up to one hour while troubleshooting. Refer to the sequence of operations for each mode, to assist in verifying proper operation. Make the necessary repairs and proceed to Steps 7 and 8.
7. If no abnormal operating conditions appear in the test mode, exit the test mode by turning the power "Off" at the main power disconnect switch.
8. Refer to the individual component test procedures if other microelectronic components are suspect.

System Status Checkout Procedure

"System Status" is checked by using one of the following two methods:

Method 1

If the Zone Sensor Module (ZSM) is equipped with a remote panel with LED status indication, you can check the unit within the space. If the ZSM does not have LED's, use Method 2. BAYSENS110*, and BAYSENS119* all have the remote panel indication feature. The LED descriptions are listed below.

LED 1 (System)

"On" during normal operation.

"Off" if a system failure occurs or the LED fails.

"Flashing" indicates test mode.

LED 2 (Heat)

"On" when the heat cycle is operating.

"Off" when the heat cycle terminates or the LED fails.

"Flashing" indicates a heating failure.

LED 3 (Cool)

"On" when the cooling cycle is operating.

"Off" when the cooling cycle terminates or the LED fails.

"Flashing" indicates a cooling failure.

LED 4 (Service)

"On" indicates a clogged filter.

"Off" during normal operation.

"Flashing" indicates an evaporator fan failure or Condensate Overflow Switch (COF) failure.

Troubleshooting

Below is the complete listing of failure indication causes.

System Failure

Check the voltage between terminals 6 and 9 on J6, it should read approximately 32 Vdc. If no voltage is present, a System failure has occurred. Refer to Step 4 in the previous section for the recommended troubleshooting procedure.

Cooling Failure

1. Cooling and heating set point (slide pot) on the zone sensor has failed. Refer to the "Zone Sensor Test Procedure" section.
2. Zone temperature thermistor ZTEMP on ZTS failed. Refer to the "Zone Sensor Test Procedure" section.
3. CC1 or CC2 24 Vac control circuit has opened, check CC1 & CC2 coils, and any of the controls below that apply to the unit (HPC1, HPC2).
4. LPC1 has opened during the 3 minute minimum "on time" during 4 consecutive compressor starts, check LPC1 or LPC2 by testing voltage between the J1-8 & J3-2 terminals on the RTRM and ground. If 24 VAC is present, the LPC's has not tripped. If no voltage is present, LPC's has tripped.

Service Failure

1. If the supply fan proving switch has closed, the unit will not operate (when connected to RTOM), check the fan motor, belts, and proving switch.
2. Clogged filter switch has closed, check the filters.

Simultaneous Heat and Cool Failure

1. Emergency Stop is activated.

Method 2

The second method for determining system status is done by checking voltage readings at the RTRM (J6). The system indication descriptions and the approximate voltages are listed below.

System Failure

Measure the voltage between terminals J6-9 & J6-6.

Normal Operation = approximately 32 Vdc

System Failure = less than 1 Vdc, approximately 0.75 Vdc

Test Mode = voltage alternates between 32 Vdc & 0.75 Vdc

Heat Failure

Measure the voltage between terminals J6-7 & J6-6.

Heat Operating = approximately 32 Vdc

Heat Off = less than 1 VDC, approximately 0.75 Vdc

Heating Failure = voltage alternates between 32 Vdc & 0.75 Vdc

Cool Failure

Measure the voltage between terminals J6-8 & J6-6.

Cool Operating = approximately 32 Vdc

Cool Off = less than 1 Vdc, approximately 0.75 Vdc

Cooling Failure = voltage alternates between 32 Vdc & 0.75 Vdc

Service Failure

Measure the voltage between terminals J6-10 & J6-6.

Clogged Filter = Approximately 32 Vdc.

Normal = Less than 1 Vdc, approximately 0.75 Vdc

Fan Failure = voltage alternates between 32 Vdc & 0.75 Vdc.

Note: *If the Condensate Overflow Switch is closed, the unit will not operate. Check to make sure the float position is not in a tripped condition and verify an "open" between wires connecting to RTOM J6-1, J6-2.*

To use LED's for quick status information at the unit, purchase a BAYSENS110* ZSM and connect wires with alligator clamps to terminals 6 through 10. Connect each respective terminal wire (6 through 10) from the Zone Sensor to the unit J6 terminals 6 through 10.

Note: *If the system is equipped with a programmable zone sensor, (BAYSENS119*), the LED indicators will not function while the BAYSENS110* is connected.*

Resetting Cooling and Heating Lockouts

Cooling Failures and Heating Lockouts are reset in an identical manner. Method 1 explains resetting the system from the space; Method 2 explains resetting the system at the unit.

Note: *Before resetting Cooling Failures and Heating Lockouts check the Failure Status Diagnostics by the methods previously explained. Diagnostics will be lost when the power to the unit is disconnected.*

Method 1

To reset the system from the space, turn the "Mode" selection switch at the zone sensor to the "Off" position. After approximately 30 seconds, turn the "Mode" selection switch to the desired mode, i.e. Heat, Cool or Auto.

Method 2

To reset the system at the unit, cycle the unit power by turning the disconnect switch "Off" and then "On".

Lockouts can be cleared through the building management system. Refer to the building management system instructions for more information.

Zone Temperature Sensor (ZTS) Service Indicator

The ZSM SERVICE LED is a generic indicator, that will signal the closing of a Normally Open switch at any time, providing the Indoor Motor (IDM) is operating. This indicator is usually used to indicate a clogged filter, or an air side fan failure.

The RTRM will ignore the closing of this Normally Open switch for 2 (±1) minutes. This helps prevent nuisance SERVICE LED indications. The exception is the LED will flash 40 seconds after the fan is turned "On" if the Fan Proving Switch is not made.

Clogged Filter Switch

This LED will remain lit the entire time that the Normally Open switch is closed. The LED will be turned off immediately after resetting the switch (to the Normally Open position), or any time that the IDM is turned "Off".

If the switch remains closed, and the IDM is turned "On", the SERVICE LED will be turned "On" again after the 2 (±1) minute ignore delay.

This LED being turned "On", will have no other affect on unit operation. It is an indicator only.

Fan Failure Switch

When the "Fan Failure" switch is wired to the RTOM, the LED will remain flashing the entire time the fan proving switch is closed, indicating a fan failure, and it will shut the unit operations down.

Condensate Overflow Switch

When the condensate overflow switch is closed, a drain pan overflow condition is indicated and it will shut unit operations down.

Zone Temperature Sensor (ZTS) Tests

Note: These procedures are not for programmable or digital models and are conducted with the Zone Sensor Module electrically removed from the system.

Test 1: Zone Temperature Thermistor (ZTEMP)

This component is tested by measuring the resistance between terminals 1 and 2 on the Zone Temperature Sensor. Below are some typical indoor temperatures, and corresponding resistive values.

| Zone Temperature | Nominal ZTEMP Resistance | Nominal CSP or HSP Resistance |
|------------------|--------------------------|-------------------------------|
| 50 F° 10.0 C° | 19.9 K-Ohms | 889 Ohms |
| 55 F° 12.8 C° | 17.47 K-Ohms | 812 Ohms |
| 60 F° 15.6 C° | 15.3 K-Ohms | 695 Ohms |
| 65 F° 18.3 C° | 13.49 K-Ohms | 597 Ohms |
| 70 F° 21.1 C° | 11.9 K-Ohms | 500 Ohms |
| 75 F° 23.9 C° | 10.50 K-Ohms | 403 Ohms |
| 80 F° 26.7 C° | 9.3 K-Ohms | 305 Ohms |
| 85 F° 29.4 C° | 8.25 K-Ohms | 208 Ohms |
| 90 F° 32.2 C° | 7.3 K-Ohms | 110 Ohms |

Test 2: Cooling Set Point (CSP) and Heating Set Point (HSP)

The resistance of these potentiometers are measured between the following ZSM terminals. Refer to the chart above for approximate resistances at the given setpoints.

Cool SP = Terminals 2 and 3

Range = 100 to 900 Ohms approximate

Heat SP = Terminals 2 and 5

Range = 100 to 900 Ohms approximate

Test 3: System Mode and Fan Selection

The combined resistance of the Mode selection switch and the Fan selection switch can be measured between terminals 2 and 4 on the Zone Sensor. The possible switch combinations are listed on the following page with their corresponding resistance values.

Test 4: LED Indicator Test, (SYS ON, HEAT, COOL & SERVICE)

Method 1

Testing the LED using a meter with diode test function. Test both forward and reverse bias. Forward bias should measure a voltage drop of 1.5 to 2.5 volts, depending on your meter. Reverse bias will show an over Load, or open circuit indication if LED is functional.

Method 2

Testing the LED with an analog Ohmmeter. Connect Ohmmeter across LED in one direction, then reverse the leads for the opposite direction. The LED should have at least 100 times more resistance in reverse direction, as compared with the forward direction. If high resistance in both directions, LED is open. If low in both directions, LED is shorted.

Method 3

To test LED's with ZSM connected to unit, test voltages at LED terminals on ZSM. A measurement of 32 VDC, across an unlit LED, means the LED has failed.

Note: Measurements should be made from LED common (ZSM terminal 6 to respective LED terminal). Refer

Troubleshooting

to the Zone Sensor Module (ZSM) Terminal Identification table at the beginning of this section.

Programmable & Digital Zone Sensor Test

Testing Serial Communication Voltage

⚠ WARNING

Live Electrical Components!

During installation, testing, servicing and troubleshooting of this product, it may be necessary to work with live electrical components. Have a qualified licensed electrician or other individual who has been properly trained in handling live electrical components perform these tasks. Failure to follow all electrical safety precautions when exposed to live electrical components could result in death or serious injury.

1. Verify 24 Vac is present between terminals J6-14 & J6-11.
2. Disconnect wires from J6-11 and J6-12. Measure the voltage between J6-11 and J6-12; it should be about 32 Vdc.
3. Reconnect wires to terminals J6-11 and J6-12. Measure voltage again between J6-11 and J6-12, voltage should flash high and low every 0.5 seconds. The voltage on the low end will measure about 19 Vdc, while the voltage on the high end will measure from approximately 24 to 38 Vdc.
4. Verify all modes of operation, by running the unit through all of the steps in the "Test Modes" section discussed in "Unit Start-Up".
5. After verifying proper unit operation, exit the test mode. Turn the fan on continuously at the ZSM, by pressing the button with the fan symbol. If the fan comes on and runs continuously, the ZSM is good. If you are not able to turn the fan on, the ZSM is defective.

Table 18. System mode and fan selection chart

| Resistance Valves (Ohms) | Zone Sensor Unit/Fan Mode | Local Unit Mode | Local Fan Mode |
|--------------------------|---------------------------|-----------------|----------------|
| 2.32K | Off/ Auto | Off | Auto |
| 4.87K | Cool/Auto | Cool | Auto |
| 7.68K | Auto/Auto | Auto | Auto |
| 10.77K | Off/On | Off | On |
| 13.32K | Cool/On | Cool | On |
| 16.13K | Auto/On | Auto | On |
| 19.48K | Heat/Auto | Heat | Auto |
| 27.93K | Heat/On | Heat | On |
| 35.0K | Emergency Heat/ Auto | Emergency Heat | Auto |
| 43.45K | Emergency Heat/ On | Emergency Heat | On |

Table 18. System mode and fan selection chart

| Resistance Valves (Ohms) | Zone Sensor Unit/Fan Mode | Local Unit Mode | Local Fan Mode |
|--------------------------|---------------------------|--------------------------|----------------|
| Out of Range (Short) | INVALID/Short | Invalid (CV), Auto (VAV) | Invalid |
| Out of Range (Open) | INVALID/Open | Invalid (CV), Off (VAV) | Invalid |

ReliaTel Refrigeration Module (RTRM) Default Chart

If the RTCI loses input from the building management system, the RTRM will control in the default mode after approximately 15 minutes. If the RTRM loses the Heating and Cooling setpoint input, the RTRM will control in the default mode instantaneously. The temperature sensing thermistor in the Zone Sensor Module is the only component required for the "Default Mode" to operate.

Unit Operation without a Zone Sensor

This procedure is for temporary operation only. The economizer and condenser fan cycling functions are disabled.

⚠ WARNING

Hazardous Voltage!

Disconnect all electric power, including remote disconnects before servicing. Follow proper lockout/tagout procedures to ensure the power can not be inadvertently energized. Failure to disconnect power before servicing could result in death or serious injury.

1. Open and Lock the unit disconnect switch.
2. Remove the Outside Air Sensor (OAS) from the condenser section of unit.
3. Use two (2) wire nuts, to individually cap the wires.
4. Locate the RTRM (J6). Connect two (2) wires to terminals J6-1 and 2.
5. Connect the sensor (OAS) using two wire nuts to the two (2) field supplied wires that were connected to terminals 1 and 2 on J6.

Unit Economizer Control (ECA) Troubleshooting

Table 19. Verify economizer status by economizer actuator (ECA) LED indicator:

| | |
|--------------|--------------------------------|
| OFF: | No Power or Failure |
| ON: | Normal, OK to Economize |
| Slow Flash: | Normal, Not OK to Economize |
| | 1/2 Second On / 2 Seconds Off: |
| Fast Flash: | Error Code: |
| | Communications Failure |
| Pulse Flash: | 2 Second On / 1/2 Second Off: |
| | Error Code: |
| 1 Flash: | Actuator Fault |
| 2 Flashes: | CO2 Sensor |
| 3 Flashes: | RA Humidity Sensor |
| 4 Flashes: | RA Temp Sensor |
| 5 Flashes: | OA Quality Sensor |
| 6 Flashes: | OA Humidity Sensor |
| 7 Flashes: | OA Temp Sensor |
| 8 Flashes: | MA Temp Sensor |
| 9 Flashes: | RAM Fault |
| 10 Flashes: | ROM Fault |
| 11 Flashes: | EEPROM Fault |

Wiring Diagrams

Note: *Wiring diagrams can be accessed via e-Library by entering the diagram number in the literature order number search field or by contacting technical support.*

Table 20. Wiring diagrams for units with High Short Circuit Rating (SCCR)

| Schematic Type | Voltage | Diagram Number | Description ^(a) |
|------------------|---------|----------------|---|
| Power | 200-575 | 1213-2121 | WS*150-240, 50/60HZ Heat Pump with or without Electric Heat |
| Controls | | 1213-2118 | WS*150-240, 50/60HZ Heat Pump with or without Electric Heat, with or without Dehumidification |
| Modules | | 2313-1550 | WS*150-240, Heat Pump |
| Component Layout | | 1213-2242 | WS*150-240, Heat Pump |

(a) * = Downflow and horizontal airflow

Warranty

Heat Pump

WSD, WSH (Parts Only)

Models Less Than or Equal to 20 Tons for Commercial Use*

This warranty is extended by Trane, to the original purchaser and to any succeeding owner of the real property to which the Heat Pump is originally affixed, and applies to products purchased and retained for use within the U.S.A. and Canada. There is no warranty against corrosion, erosion or deterioration.

If any part of your Heat Pump fails because of a manufacturing defect within one year from initial start-up or 18 months from date of shipment - whichever is lesser- Warrantor will furnish without charge the required replacement part.

In addition, if the sealed motor-compressor fails because of a manufacturing defect within the second through fifth year from the date of original purchase, Warrantor will furnish without charge the required replacement compressor. Warrantor's obligations and liabilities under this warranty are limited to furnishing F.O.B. Warrantor factory or warehouse replacement parts for Warrantor's products covered under this warranty. Warrantor shall not be obligated to pay for the cost of lost refrigerant. No liability shall attach to Warrantor until products have been paid for and then liability shall be limited solely to the purchase price of the equipment under warranty shown to be defective.

THE WARRANTY AND LIABILITY SET FORTH HEREIN ARE IN LIEU OF ALL OTHER WARRANTIES AND LIABILITIES, WHETHER IN CONTRACT OR IN NEGLIGENCE, EXPRESS OR IMPLIED, IN LAW OR IN FACT, INCLUDING IMPLIED WARRANTIES OF MERCHANTABILITY AND FITNESS FOR PARTICULAR USE, AND IN NO EVENT SHALL WARRANTOR BE LIABLE FOR ANY INCIDENTAL OR CONSEQUENTIAL DAMAGES.

Some states do not allow limitations on how long an implied warranty lasts or do not allow the exclusion or limitation of incidental or consequential damages, so the above limitation or exclusion may not apply to you. This warranty gives you specific legal rights, and you may also have other rights which vary from state to state.

Trane
2701 Wilma Rudolph Blvd.
Clarksville, TN 37040-1008
Attention: Manager, Product Service
GW-604-4800

* This warranty is for commercial usage of said equipment and not applicable when the equipment is used for a residential application. Commercial use is any application

where the end purchaser uses the product for other than personal, family or household purposes.

*A 5 year limited warranty is provided for the optional Low Leak Economizer, when combined with the optional FDD (Fault Detection & Diagnostics) option.

Trane and American Standard create comfortable, energy efficient indoor environments for commercial and residential applications. For more information, please visit trane.com or americanstandardair.com.

Trane and American Standard have a policy of continuous product and product data improvement and reserve the right to change design and specifications without notice. We are committed to using environmentally conscious print practices.